



USER MANUAL

G 50 J2 ST Gaming Machine



(rev. 3.0)

©2021 - 2022, Euro Games Technology Ltd.
www.egt.com

Revision History

Version	Date	Changes
rev. 1.0	April 2021	An initial document version
rev. 3.0	February 2023	<p>A new document version with the following changes:</p> <ul style="list-style-type: none"> • A new opportunity that the gaming machine can work with an Exciter IV gaming platform is added. • Exciter IV platform description is added. • The chapter Connectors of Backplane Board is updated. • The modular diagrams of Components are updated. • New bill validator models that the machine supports are added. • The models of Bill Validators and Ticket Printers, as well as their technical characteristics, are listed in the Applications section.

The manufacturer shall reserve its right to make changes and amendments to the item and documentation without prior notification of the customer.

Signs Used

Warning!

Warns about specific conditions or situations, which require due attention.

Note:

Gives important or additional information.

Contents

Revision History	2
Signs Used	3
Introduction	6
General Description	6
Technical Specifications	7
Dimensions	7
Operating Conditions.....	8
Transportation	8
Safety and Precaution Measures	9
Installation and Gaming machine Service	10
Visual Inspection	10
Gaming Machine Installation Requirements	10
Doors Opening and Closing	11
Top Lamp Mounting	14
Control Keys.....	16
Forming a Credit	16
Cashing Out the Player's Credit	18
Machine Reservation and Release	19
Top Lamp (Signal Lights)	20
Component Maintenance.....	21
Hardware Components.....	23
General Description of Components	23
Power Distributor Units (PDU) and Power Supply Units (PSU)	26
Specialized Gaming Platform.....	27
Monitors	27
Bill Validator (Option)	28
Ticket Printer (option)	28
Keyboard Panel.....	28
Meter Module.....	29
Signal Lights Controller	29
Decorative Lighting.....	30
i-Buttons Reader and Socket	30
Audio System	30
Door Switches	31

Cabinet Identification31

Gaming Machine Troubleshooting32

 Troubleshooting.....32

 Fuse Replacement.....32

 Error Messages32

Applications33

 Bill Validator Models and Technical Parameters33

 Ticket Printers Models and Technical Parameters45

 Modular Diagrams of Components48

 Connectors of Backplane Board57

Contacts61

Introduction

General Description

- G 50 J2 ST gaming machines are designed for use in casinos and gambling halls.
- The cabinet is powered by the Exciter III or Exciter IV gaming platform, specially created by Euro Games Technology (EGT) that complies with the newest requirements of the gaming industry.
- The machine is specially designed for more ease of use.
- The cabinet has a stylish design combining high comfort with modern aesthetics, an efficient platform, frameless UHD displays with high visual quality, a convenient keyboard, crystal clear stereo sound, and easy maintenance.
- The machine is made of high-quality materials and equipped with all necessary periphery devices and modules.
- The main overview of the G 50 J2 ST gaming machine is shown in the picture below:



Technical Specifications

Name	Value
Manufacturer	Euro Games Technology Ltd., Bulgaria
Type	EGT-VS33
Power Supply Voltage	100 - 240 V AC
Current	4.5 - 1.9 A
Consumption	410 W
Frequency	50 - 60 Hz
Fuses	
General Power Distributor	F1, F2 - T 10A / 250V~ - for the gaming machine; F3, F4 - T 3.15A / 250V ~ - for external peripheral devices connected to the gaming machine.
Low Voltage Distributor	F1 - ATC 20A / 12V DC F2 - ATC 5A / 24V DC

The identification plates are located on the side of the cabinet.

Dimensions

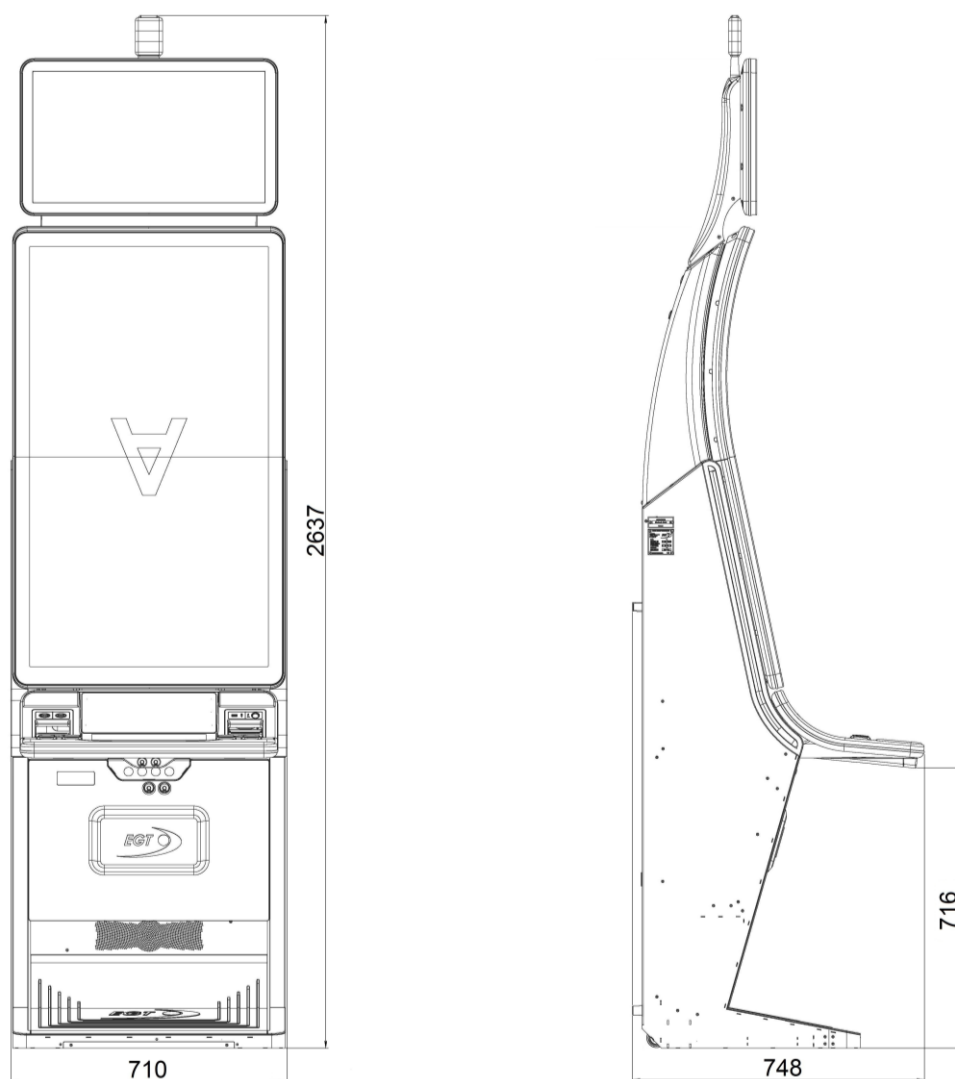

Dimensions	Values
Gross weight without topper	215 kg
Net weight without topper	203 kg
Gross weight of topper	25 kg
Net weight of topper	22 kg
Height with Topper	2 637 mm
Height without Topper	2 205,4 mm
Width	711 mm
Depth	749 mm

Note:

The indicated height is with a top lamp mounted.

Operating Conditions

This gaming machine is designed and manufactured to keep its operability at the following conditions:

Parameter	Value
Ambient temperature	from +10C° to +30C°
Relative humidity	from 20% to 80%
Operation position	vertical
Power supply voltage	100 - 240 V~ (from -10% to +10%), 50 ÷ 60Hz
Used in	indoors

Transportation

Move the machine only when the power is switched off.

The cabinet must be placed in a vertical position upon transportation. It must be in a stable position, secured against moving and mechanical impact upon transportation. The cabinet is fixed to the pallet with a plate on the back and a transport belt on the step.



The Top Lamp travels in a separate package placed inside the gaming machine. The Top Lamp is mounted to the topper when the gaming machine has a topper.

Transport box dimensions:

Gaming machine	900 x 900 x 2 300 mm
Topper (option)	750 x 740 x 275 mm

Warning!

After transporting or moving of the machine from a colder to a warmer premise, please wait at least two hours before switching it on in order to avoid humidity condensation.

Safety and Precaution Measures

- The gaming machine is a device with protection class I in terms of protection against electric shock according to the requirements specified in EN 60335-1.
- Connect the machine only to a two-pole power socket with the protective grounding of the electric wiring.
- Place the machine on the premise in such a manner that the eclectic plug is easily accessible.

Warning!

- Move the gaming machine only when all the doors are closed and locked.
- Grasp the machine using the handles provided, located on the back of the gaming machine.



- Tilt the gaming machine slightly back to lean on the wheels only.



- Always disconnect the power cord of the gaming machine from the socket when performing any repairs or servicing at open doors.
- Do not grasp or press on the glass (touch screen) of the gaming machine.
- In case of power cord damage, replace it with a special cord or cord set, supplied by the manufacturer or its representative.
- Replace the fuses only with new ones, complying with the parameters of the original fuses.

Do not:

- Operate the machine outdoors.
- Operate the machine indoors with high humidity.
- Install and use the machine where it can be exposed to water drops or sprinkles.
- Operate close to heating units or expose to direct sunlight.
- Pour the machine with any liquids. In case if it happens, immediately disconnect the power plug from the socket and call the service specialist.
- Cover ventilation outlets on the machine body.
- Drop anything into the ventilation outlets.
- Kick and/or hit the gaming machine.
- The machine is not designed to be used by persons (including children) with reduced physical, sensory, or mental abilities, or by persons with a lack of experience and knowledge unless they have a supervisor or instructor responsible for their safety.
- Children should be supervised to not play with the gaming machine.

Installation and Gaming machine Service

Warning!

Before switching on the machine for the first time, please carefully read and understand this User Manual.

Visual Inspection

Before installation, inspect visually the gaming machine for possible shipping damage.

Warning!

The manufacturer shall not bear liability for damages that occurred upon the transportation of the gaming machine.

Gaming Machine Installation Requirements

To ensure proper operation of the machine the preliminary operations, described below shall be performed:

- Place the machine in a vertical position;
- Upon installation ensure at least 10 cm cooling space behind the back of the machine;
- Check for disconnected cables and connectors inside the cabinet;
- The machine is designed for the following voltages: 100 - 240 V~ (from -10% to +10%), 50 ÷ 60Hz;
- Place the power cable and connect it to the power mains;
- Turn the main power switch on and wait for the appearance of a picture on the screen;
- Teach the software in the iButton Reader to recognize EGT electronic keys (see EGT Electronic Keys_ iButton Reader Teaching_Service_Manual_EN_0x.pdf or contact the EGT Service);
- Insert OWNER key and set up the desired machine and game parameters;
- Check the operation of the rest keys and devices used for credit forming and payout.

Doors Opening and Closing

Access to the main electronic components of the gaming machine located in its body is done by opening Main Door 1, Main Door 2 and Bill Validator Door. The access is restricted by a locking system with a secret lock, which is controlled even when the power of the gaming machine is turned off.

Main Door 1 Opening and Closing

Main Door 1 Opening

1. Insert the corresponding Main Door Key in the left lock and turn it clockwise. The lock is located under the keyboard.



Note:

In accordance with the requirements in certain jurisdictions, to unlock the main door 1 may take two passkeys. The second secret lock is also available as an option at the customer's request.

- 1.a. Put the corresponding passkey (Main Door Key 1) in the lock 1 (right) and turn it clockwise. The lock is located below the keyboard.



- 1.b. Put the corresponding passkey 2 (Main Door Key 2) in the lock 2 (left) and turn it clockwise. The lock is located below the keyboard.



2. Grab the Main Door 1 at the keyboard part and pull the door towards you.



Main Door 1 Closing

1. Grab the Main Door 1 opened at the keyboard part and slide forward until full closing.



Main Door 2 Opening and Closing

Main door 2 Opening

1. Open the Main Door 1.
2. Pull the Lever for Main Door 2 opening.



Note:

Make sure the PULL lever is returned to its original position.



3. Grasp Main Door 2 with both hands and lift the door up until the lift mechanism is securely locked.



Main Door 2 Closing

1. Pull the lever to open Main Door 2 to unlock the blocking mechanism.



Note:

Make sure the PULL lever is returned to its original position.

2. Grasp Main Door 2 with both hands and pull down until the door is completely closed.

Warning!

In slot machines equipped with Main Door 2 handles, there is a locking mechanism that prevents closing Main Door 1 before Main Door 2 is completely closed.

Bill Validator Door Opening and closing

Bill Validator Door Opening

1. Unlock the Bill Validator Door with the corresponding passkey. The lock is located below the keyboard, in the middle.



2. Open the door by gently holding it until full opening.

Bill Validator Door Closing

1. Lift up the Bill Validator door.
2. Press forward and lock the door.

Safety Sheet Opening and Closing

To gain access to the power supply units and power supply distributors, it is necessary to open the Safety Sheet.

Safety Sheet Opening

1. Open the Bill Validator Door.



2. Open the Main Door 1.
3. Pull the Main Door 1 about 10 cm toward yourself.
4. Pull the handle A shown in figure below.

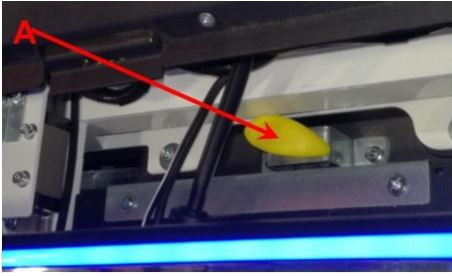

5. The Safety Sheet opens

Safety Sheet Closing

1. Close the Safety Sheet by lifting it upwards.
2. Press until the Safety Sheet is tightly closed.

Top Lamp Mounting

The gaming machine is transported to the customer with an unmounted Top Lamp. To mount the Top Lamp, follow the instructions below:

1. Unlock and open Main Door 2 of the gaming machine.
2. Remove the support plate by unscrewing screw M4x16 - 1 pc. and nut M6 - 2 pcs.

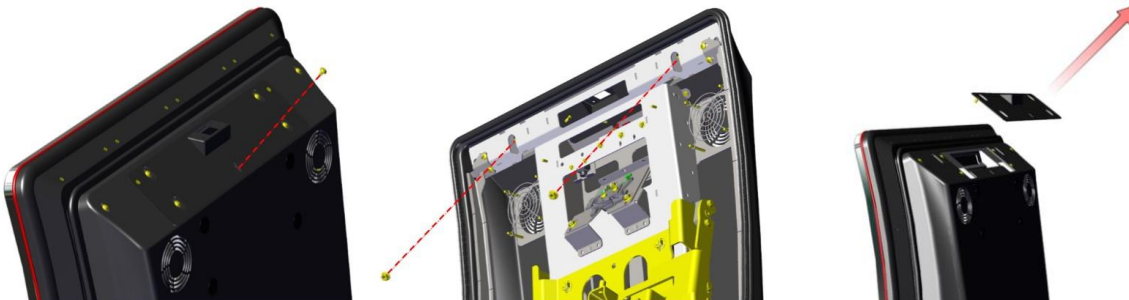

* For better visualization, the gaming machine monitor is not displayed.

3. Pass the signal lamp cable and ground wire through the mounting plate hole. Fix the top lamp with screw M3x6 - 2 pcs.

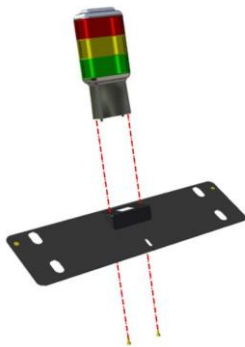

4. Connect the ground wire of the top lamp to the stud provided on the support plate.

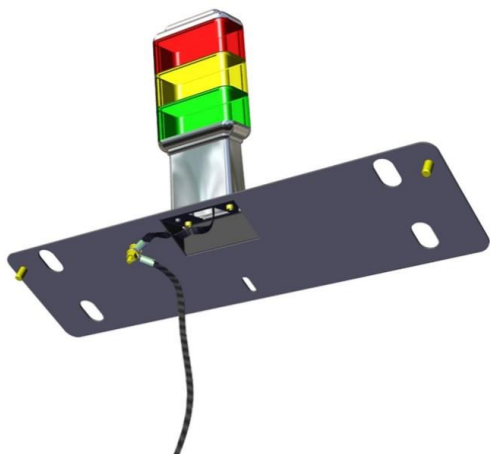

Warning!

The ground wire between the plate and the gaming machine body must remain connected to the same ground

5. Connect the top lamp to the corresponding electrical connector mounted on a connectors plate inside the gaming machine.

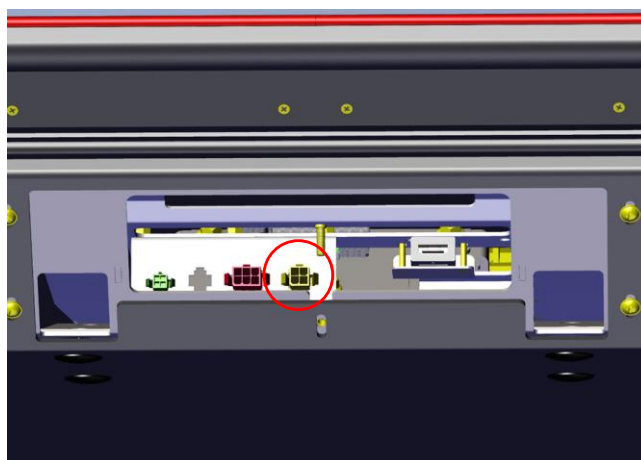

6. Install the support plate by fixing it with screw M4x16 - 1 pc. and nut M6 - 2 pcs.



* For better visualization, the gaming machine monitor is not displayed.

Note:

The mounting and installation of the Topper General (option) is a subject of a separate user manual.

Control Keys

By using the electro-mechanical key, you can access the credit forming screen, the service functions, the accounting of the machine, or the games.

Electronic/Mechanical Key	Purpose of Use
ATTENDANT	By the ATTENDANT key, you can: <ul style="list-style-type: none"> • Form the player's credit or payout it by hand; • Clear the jackpot splashes; • Unblock the machine operation in some of the failures.
CASHIER	By the CASHIER key you can: <ul style="list-style-type: none"> • Realize access to the machine service functions without the setup menus and Clear Period Accounting menu.
ADMIN	By the ADMIN key, you can: <ul style="list-style-type: none"> • Realize access to the machine service functions, including the Clear Period Accounting menu, without setup menus.
OWNER	By the OWNER key, you can: <ul style="list-style-type: none"> • View detailed statistics; • Perform the machine setup; • Access all menus of the machine service functions.

Forming a Credit

To start a game, the player has to form a credit, from which the bet during a game is taken.

Depending on the machine settings, there are three ways to form a credit:

- [Forming a credit via an Attendant key.](#)
- [Forming a credit via a Bill Validator.](#)
- [Forming a credit via a Player's Card.](#)

Prerequisites

- The player forms a credit when the credit is 0.
- The player can increase the value of available credit by adding a new amount when the previous game is ended.
- Forming/adding a credit can be done in the Select a game screen or in the main screen of the game.

Note:

After forming/adding a credit the player credit cannot be bigger than the credit limit, set in the machine service functions.

Forming a Credit via an Attendant Key

This procedure is for the service staff (attendant) in the casino, who uses a special key to insert credit.

Warning!

In countries where the legislation prohibits the addition of credits by the attendant, using his key, this option is disabled.

1. Insert the Attendant key into the iButton Reader socket, on the right, over the bill validator entrance.

The window, shown below, appears on the screen:

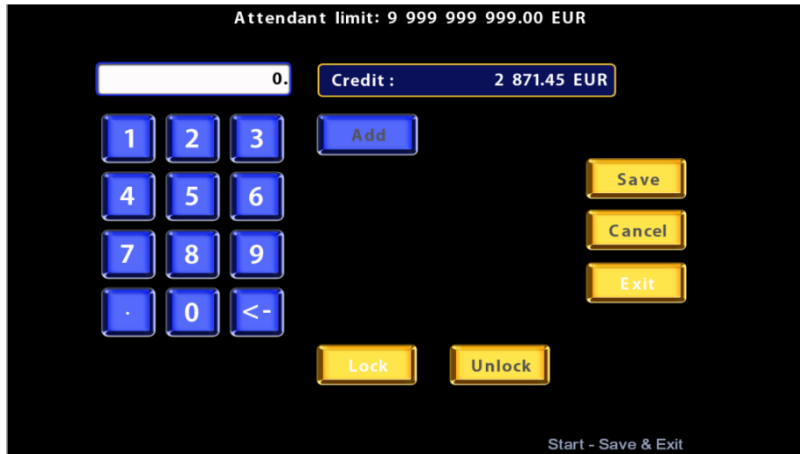

2. Enter the necessary number by touching the digit keys on the touch screen keyboard.
If a wrong digit is chosen, press <-.
- The credit value is inserted in money in the selected currency and displayed in the **Credit** field.
3. Press the **Add** button.
4. Press the **Cancel** button if the newly inserted credit value is wrong, and enter again.
5. Press the **Save** button to save the inserted credit value.
6. Insert a new credit value if the **Attendant Limit** sign starts blinking, which means that the new credit value exceeds the Credit limit, set in the machine service functions.
7. Press the **Exit** button to return to the game.

Forming a Credit via a Bill Validator

Note:

There must be a bill validator in the machine, and it has to be enabled and set in the machine initial setup.

1. Insert the banknote, or ticket, or voucher into the bill validator entrance:

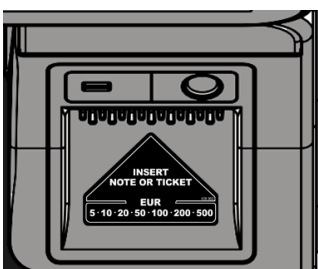

Note:

Make sure that the banknote used has a nominal and currency corresponding to those written on the sticker at the bill validator entrance. The type of banknotes that can be accepted is defined during the initial setup of the machine.

2. The **CREDIT** field updates with the inserted banknote value.
3. Select a game in the select a game screen to play, or start a game in the main game screen.

Forming a Credit via a Player's Card

- Cashless systems allow players to play gaming machines through the use of a player card, which accesses a player's account at the host system in the casino.
- Forming a credit via the player card applies to the gaming machines in which a casino management system is built and supported.
- The player inserts his card into the card reader entrance that allows the deduction of the credits to be placed into the machine, and the player has the opportunity to play and win with them.

Cashing Out the Player's Credit

The cashing out procedure starts after pressing the **CASH OUT** button, located at the top left part of the keyboard panel:

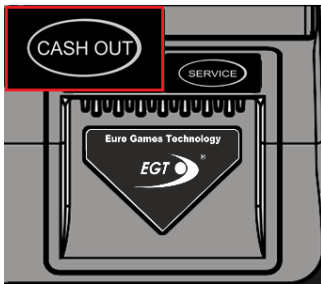

Depending on the machine settings, there can be three ways to pay out the credit:

- *Cashing Out by Attendant - Handpay*
- *Cashing Out via a Ticket Printer*
- *Cashless Payment via the Player's Card*

Prerequisites

- The game has to be ended.
- The player's credit is greater than zero and the player does not want to play anymore.

Cashing Out by Attendant - Handpay

1. Press the **CASH OUT** button.

Call Attendant Handpay splash appears on the center of the screen:



2. Press the **SERVICE** button, placed on the right, over the ticket printer exit, to call the attendant.

The attendant gives to the player the amount of credit in money, written on the splash, by hand (cash).

Cashing Out via a Ticket Printer

Note:

To perform this procedure there must be a ticket printer in the machine, and it has to be enabled and set in the machine initial setup.

1. Press the **CASH OUT** button.

The ticket printer prints the voucher, ticket, or receipt with the amount of the player's credit.

2. Receive the ticket from the ticket printer exit.

Cashless Payment via the Player's Card

- The cashless systems allow players to play on gaming machines through the use of a card, which accesses a player's account at the host system in the casino.
- Once play is complete the player has several options, depending on the built casino management system:
 - to move some of the credits back to the player's account or cash out some credits;
 - to transfer the entire credit value back to the system.

Machine Reservation and Release

1. Insert the **Attendant** key.
 - The window, shown in the picture below, appears on the screen:



2. Tap the **Lock** button to reserve (LOCK) the machine.
3. Tap the **Exit** button.
 - The game picture with the **RESERVE** sign appears on the screen.
 - The machine is locked for playing or the credit changing until you unlock it.
4. Tap the **Unlock** button to release (UNLOCK) the machine.

Top Lamp (Signal Lights)



- The Top Lamp is mounted on the top of the machine.
- It consists of 3 signal lamps (lights) that are colored in three colors - red, yellow, and green.

Note:

For some markets the colors/number and their functions may differ from those described.

- Each lamp lights up at determined conditions and indicates different states of the machine depending on the software product installed in the machine.

Lamp	Color	Name	Conditions/ Lighting Mode
Top Lamp	Red	Hand Pay	<p>This lamp starts blinking at 1 sec. intervals in the following cases:</p> <ul style="list-style-type: none"> • at Local/Host Jackpot when a greeting splash appears on the screen; • at Mystery Bonus when a greeting splash appears on the screen; • at Handpay when a splash appears on the screen. <p>The lamp goes off at the machine unblocking.</p>
Middle Lamp	Yellow	Open Door	<p>This lamp starts blinking counter-phase to Lamp 3 in the following cases:</p> <ul style="list-style-type: none"> • at door opening; • at entering into Service Functions with Owner key and credit = 0. <p>The lamp goes off after eliminating the reason, it leads to activation thereof.</p>
Bottom Lamp	Green	Tilt/Change	<p>This lamp is activated in the following cases:</p> <ul style="list-style-type: none"> • at Service button activation; • in case of fatal, non-fatal software error or warning; • in case of entering into Calculator; • at a demonstration of splashes on network conditions. <p>The lamp goes off:</p> <ul style="list-style-type: none"> • at Service button deactivation; • after the error or warning cleanup; • right after closing the calculator; • right after disappearing of splashes on network conditions. <p>Blinking mode:</p> <ul style="list-style-type: none"> • blinks at 500 ms in phase with Hand Pay Lamp (red) and counter-phase with Open Door Lamp (yellow); • only in Calculator mode, the lamp continuously lights and goes off when exiting from this mode.

Component Maintenance

Component	Description	Recommended Maintenance Period	Cleaning
Exciter III or Exciter IV Main Board and Exciter III or Exciter IV Connectors Board	Accumulation of dust on the fan and the processor radiator impairs its cooling and may hinder its normal operation.	Monthly	Clean the dust from the fan and the processor radiator. Use a vacuum cleaner. Clean only when the power is switched off! For prevention, you may contact the nearest authorized EGT service center.
Monitors/ Touchscreen	Upon normal operation, a part of grease and contamination on players' fingers remain on the touchscreen, which may impair its sensitivity in some zones.	Minimum once a week, recommended after each client.	With a soft cloth and glass cleaning liquid. Do not allow leakages of cleaning chemicals and soaking of seals. In most cases, this leads to interruption or full blocking of device operation.
Cabinet Fans	Accumulation of dust on the fans impairs machine cooling and may become an obstacle to its normal operation.	Each three months	Use a vacuum cleaner. Clean only when the power is switched off! If a fan stops working or works with a high noise level, it should be replaced by a new one with the same model.
Bill Validator	Upon normal operation dirt from bills is transferred into the device and accumulated on pressing rolls, magnetic head, and optical sensors of the unit.	Depending on ambient conditions. In normal conditions, the cleaning shall be carried out every six months. At severe operation conditions, such as polluted, dusty environment, and/or such with high relative humidity or high level of micro-particles, it is recommended to perform cleaning more often.	The cleaning shall be performed with a piece of soft cloth, which shall not leave lint on surfaces, soaked with 90% isopropylene alcohol. Clean only when the power is switched off!
Ticket printer	Upon normal operation accumulation of dust on the paper might reduce printing quality.	Depending on ambient conditions. In normal conditions, the cleaning shall be carried out every six months. In severe operation conditions, such as polluted and/or dusty environments, it is recommended to perform cleaning more often.	Cleaning is done using a soft brush. If the thermal head needs cleaning, use a thermal printer cleaning card.

Component	Description	Recommended Maintenance Period	Cleaning
Keyboard Panel	<p>The system controls the condition of the LED button (if the test is enabled in machine setup) and displays an error message in case of a short circuit or disconnected LED module.</p>		<p>Problem Solving: The defective LED module is replaced by a new one. Replace the LED module only when the machine power is switched off!</p>
Electro-mechanical Meters	<p>There are 6 electro-mechanical meters installed in the machine. The machine controls the condition of the electro-mechanical meters and displays an error message in case of a short circuit or disconnected meter. In this case, check the meter circuit. If the defect is in the meter itself, it shall be replaced by a new one of the same types.</p>	<p>After a long-time of operation, some of the meters begin to partially or fully fail to count. Although they are electrically fit, in this case, they shall be replaced by new ones.</p>	

Hardware Components

General Description of Components

View of the Cabinet with All Doors Closed:



Inside View of the Main Door 1 Opened with Cover

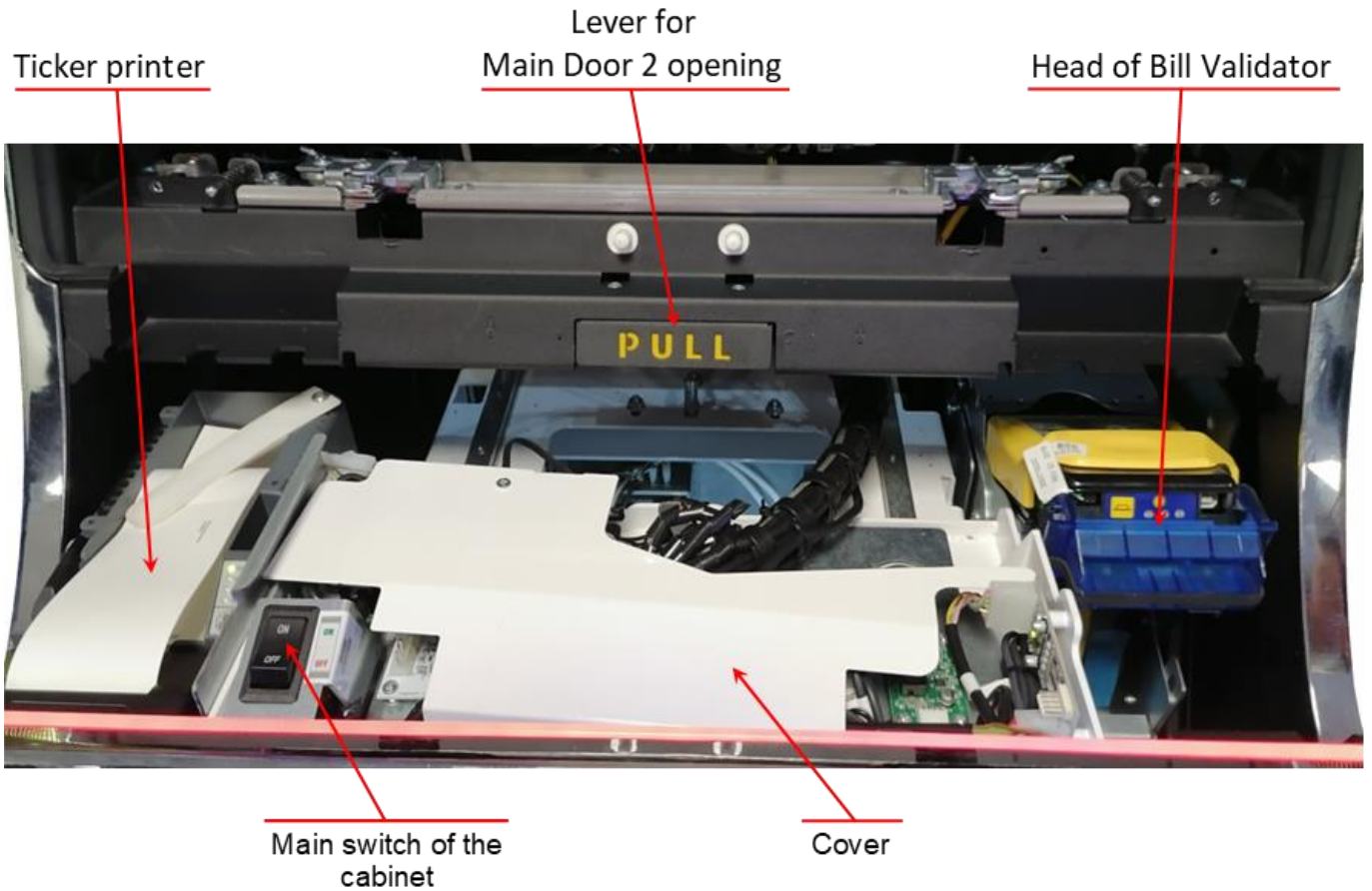

Inside View of the Main Door 1 Opened without Cover

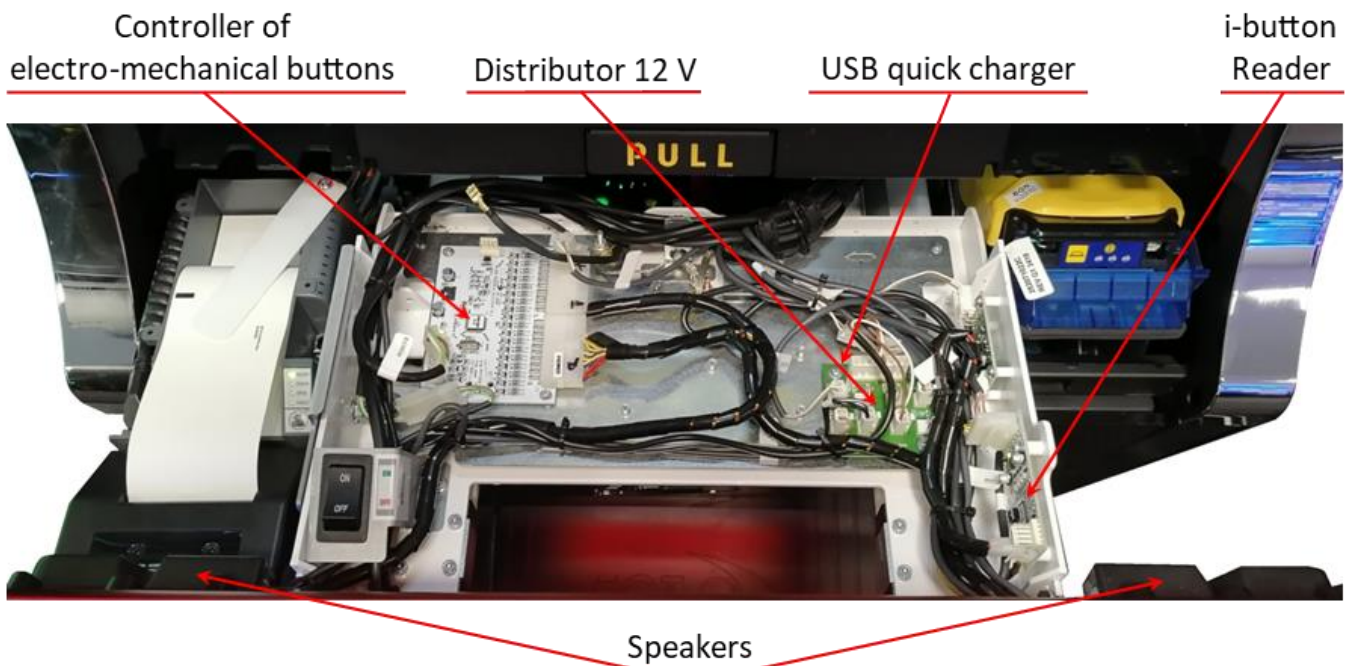

Inside View at the the Main Door 2 Opened

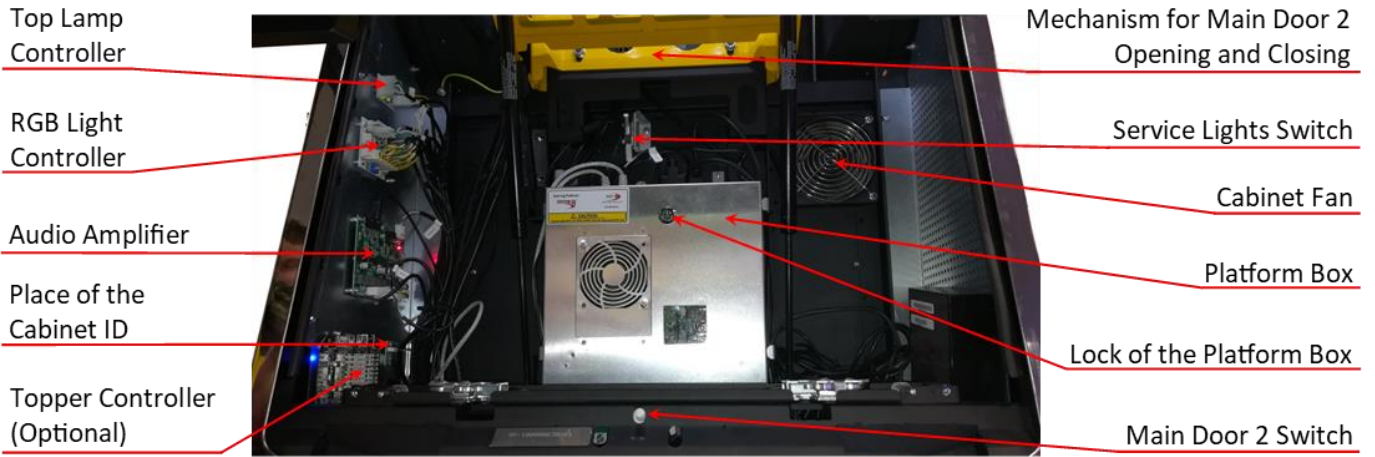

Inside View at the Bill Validator Door Opened



Inside View at the Bill Validator Door and Safety Sheet Opened

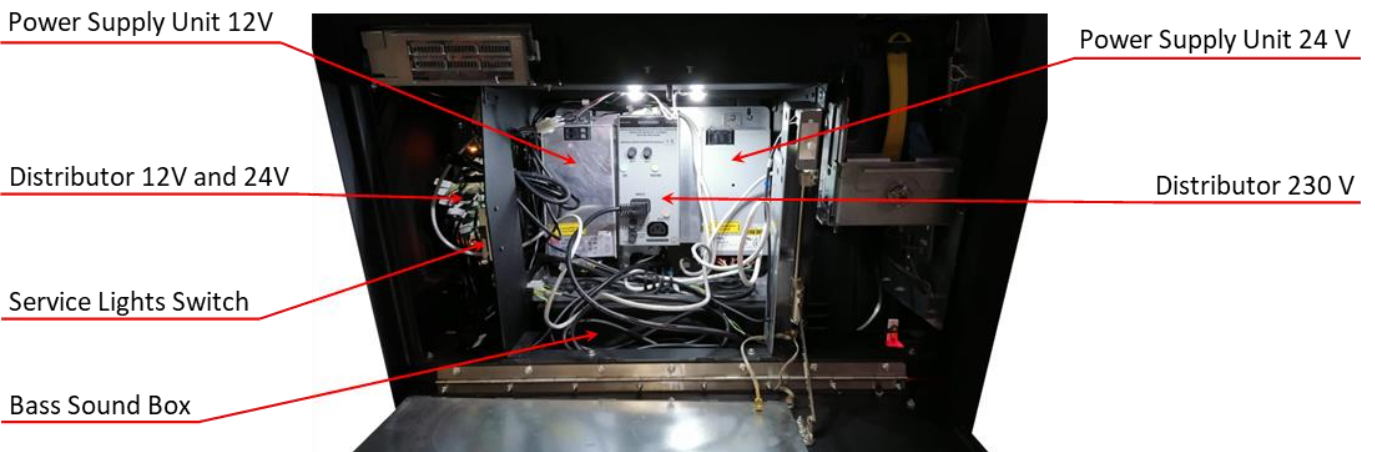

All the electronic components of the machine are located in the body, on Main door 1, Main door 2 and behind Bill Validator Door, and behind Safety Sheet. The access is restricted by a locking system with a secret lock, which is controlled even when the power of the gaming machine is turned off.

Power Distributor Units (PDU) and Power Supply Units (PSU)

Type	Kinds	Description
Power Distributors	General Power Distributor Module	Power Distributor Unit 230 V
	Low Voltage Distributor	Power Distributor Unit 12 V and 24 V
	12 V Power Distributor	Power Distributor Unit 12 V
Power Supply Units	PSU 12 V, 300 W	Power Supply Unit 12 V
	PSU 24 V, 300 W	Power Supply Unit 24 V

Purpose of Use

Kinds	Purpose of Use
General Power Distributor Module	It supplies input voltage to power supply units and additional peripherals.
Low Voltage Distributor	It supplies input voltage to the gaming platform, the upper monitor, the lower monitor with a touchscreen, the cabinet fans, the RGB lights controller, the topper controller, the Power Distributor Unit 12V and the USB quick charger.
12 V Power Distributor	It supplies input voltage to the keyboard monitor with a touch screen, the decorative lights, the white LED Lights, and the USB adapter.
Power Supply Unit 12 V	They supply DC voltage to the Low Voltage Distributor and 12 V Power Distributor .
Power Supply Unit 24 V	

Technical Parameters

Power Supply Units		
Parameter	Value	
Input Voltages	100 ÷ 240 V AC	50 ÷ 60 Hz
Rated output voltage and current	12V DC	25 A
Rated output voltage and current	24V DC	6.25 A
General Power Distributor Module		
Input Voltage	100 ÷ 240 V AC	50 ÷ 60 Hz
Output Voltage	100 ÷ 240 V AC	50 ÷ 60 Hz
Fuses: 2 pcs. T10A/250V and 2 pcs. T3.15A/250V		
Low Voltage Distributor – 12 and 24 V DC		
Fuses: 2 pcs. ATC-20A for 12V and ATC 5A for 24V		
12 V Power Distributor – 12 V DC		

Specialized Gaming Platform

- The specialized gaming platform is the managing computer in the gaming machine.
- The gaming machine can work with one of the two developed by the Euro Games Technology gaming platforms - Exciter III or Exciter IV.

Exciter III - Specialized Gaming Platform

Type	Exciter III Gaming Platform	
Components	<ul style="list-style-type: none"> • Exciter III Motherboard • Backplane Board • Gaming Board 	DPX-W250

- Insert the **SATA Flash** Card with the operating system (OS) on the **SATA 1** connector.
- Insert the **SATA Flash** Card with the game software on the **SATA 2** connector.
- The **BIOS** memory and **NVRAM** backup battery are located on the **Exciter III gaming board**.
- There are **4 DIP** switches and one of them (switch 1) is used for a machine memory reset.

Exciter IV - Specialized Gaming Platform

Type	Exciter IV Gaming Platform	
Components	<ul style="list-style-type: none"> • Exciter IV Motherboard • Backplane Board • Gaming Board 	DPX-M270 set

- There are **4 DIP** switches and one of them (switch 1) is used for a machine memory reset.
- The **Exciter IV** platform works with an **M.2** data storage device where the game and system program are stored.
- Installing and updating of the game software takes place without changing the physical media.
- The **Exciter IV** platform has a video output for direct visualization of information on the topper screen.

Monitors

Type	<ul style="list-style-type: none"> • 50" vertical curved monitor with touch screen; • Dynamic Touch Keyboard 13,3" monitor with a touchscreen.
------	--

Purpose of Use

Monitors	Display the game, help screens, error messages, settings and service functions.
Touchscreens	Ensure an additional interface between the player and the machine during a play and in the service functions.

Bill Validator (Option)

Purpose of Use

- The bill validator validates and accepts bills, inserted by the player. It is programmed for the appropriate currency.
- Maintains the communication with the gaming platform:

Platform	Exciter III	Exciter IV
Communication Interface	True RS232	True RS232 or USB

Note:

For detailed information about bill validator models supported by the machine, their technical parameters, see the corresponding chapter *Bill Validators, used in the gaming machine* in the Applications.

Ticket Printer (option)

Purpose of Use

The printer prints vouchers and tickets when credits are cashed out from the gaming machine.

Note:

For detailed information about ticket printer models supported by the machine, their technical parameters, see the corresponding chapter *Ticket printers, used in the gaming machine* in the Applications.

Keyboard Panel

Type

The Keyboard panel consists of two parts:

- The Dynamic Touch Keyboard is controlled by the Exciter III/Exciter IV platform.
- The electro-mechanical buttons are controlled by the USB Keyboard Controller.
- The picture below displays an example of the gaming machine keyboard panel. The location, names, and functionalities of the buttons depend on the type of multigame installed on the gaming machine.



Purpose of Use

Keyboard Controller	<ul style="list-style-type: none"> • Transfers information on the condition of keyboard panel buttons and/or their LEDs; • Maintains communication with Exciter III or Exciter IV; • Tests the button LEDs for disconnections or short circuits.
Keyboard Panel	Carries out the communication between the user and the machine during a game and service functions.

Technical parameters

USB Keyboard Controller:

Parameter	Value
Number of buttons controlled	up to 18
Number of LEDs controlled	up to 18
Power	+12V, 0.4A max

Meter Module

Type

General Counters Module

Purpose of Use

- counts the impulses, transferred by the control platform to the appropriate mechanical meters;
- transfers information on the condition of mechanical meters;
- maintains communication with Exciter III Motherboard or Exciter IV Motherboard;
- tests meters for disconnected or short circuit ones.

The meter test is performed by the test mask, which is set from the machine service menu.

Technical Parameters

Parameter	Value
Number of meters controlled	6
Power	+12V, 1.25A max.

Signal Lights Controller

Type

Top Lamps Ctrl

Purpose of Use

- controls the signal lights in accordance with the commands received;
- maintains communication with Exciter III Motherboard or Exciter IV Motherboard.

Technical Parameters:

Parameter	Value
Number of signal lights controlled	3
Power	+12V, 0.2A max.

Decorative Lighting

Type	Place in the gaming machine
white lighting	<ul style="list-style-type: none"> the EGT logo; at the Bill Validator entrance; at the Ticket Printer exit.
The RGB lighting is situated around:	<ul style="list-style-type: none"> the upper monitor; the lower monitor; footstep; the cabinet body sides.

Purpose of Use

Gives an attractive look to the machine.

i-Buttons Reader and Socket

Type

- i-Button Reader;
- DS9092 Socket.

Purpose of Use

Allows access of the authorized staff to settings, service functions, and reports of the gaming machine.

Audio System

Type

Audio system consists of speakers situated on Main Door and a Bass Sound Box.

Purpose of Use

Plays stereo sound.

Technical Parameters

Speakers situated on the Main Door:

Parameter	Value
Type	Broadband
Impedance	8 Ω
Power	10 W

Bass Sound Box

Parameter	Value
Impedance	4 Ω
Power	50 W

Door Switches

Type

Push-Pull.

Purpose of Use

The switches detect openings and closings of all doors.

Cabinet Identification

Type

Cabinet ID

Purpose of Use

It uniquely determines the type of gaming machine - number of monitors, type of monitors, resolution of monitors, orientation of monitors - horizontal or vertical.

Gaming Machine Troubleshooting

Troubleshooting

External features	Possible cause	Solution
Nothing lights up	Fuse burned out	Replace the fuse.
	Power Cord	Replace the power cord
	Main Power Supply Unit (PSU)	Check the PSU LED. Replace the PSU.
Buttons don't work	Defective button	Replace the button.
	Problems with connection to the keyboard controller	Check the keyboard controller connections.
Electro-mechanical Meters	Defective meter	Replace the meter.
	Problems with the connection to the meter's controller.	Check the meters controller connections.
The touchscreen does not work	Problems with the connection between controller and control computer.	Check the connection cable and replace it if necessary.
	Touchscreen controller defective	Replace the touchscreen controller
No sound and picture, only decorative lighting works	Problems with the control computer.	Check the power of the control computer. Check the game platform. Replace defective modules.

Fuse Replacement

- During the operation of the gaming machine, it can become necessary to replace fuses.
- For this purpose, unplug the machine power plug from the socket of the power mains!
- The new fuses must be with the same parameters as the original ones (see Technical Specifications and Dimensions).

Error Messages

- During the operation of the gaming machine, several events or errors can occur.
- The events are only registered in the service functions in the **All-Events Log** menu.
- The errors that occur are displayed on the machine screen in a form of a message. The error is cleared when its cause is solved.
- Connect to the EGT service desk and report the information in the error message if you cannot solve the problem.

Applications

Bill Validator Models and Technical Parameters

Type

MEI SCN8347(E)	Cashcode Type MFL	JCM UBA-10-SS	JCM iPro
			
JCM iVizion	NV 200	NV 200 Spectral	iCT NBA
			
JCM UBA PRO 500SS			
			

Note:

The bill validators **NV 200** and **NV 200 Spectral** are used only in a gaming machine with the **Exciter IV** platform.

Technical Parameters

MEI SCN 8347(E)		
Electrical Parameters		Value
Power Supply Voltage		12 ÷ 28 V DC ± 5%
Current consumption	Standby	0.45 A
	Operating mode	1.25÷3.0 A
Communication Interface		USB
Environment Parameters		Value
Operation Temperature		0° C ÷ +60° C
Operating Relative Humidity		5% ÷ 95%
Storage Temperature		-30° C ÷ +70° C
Acceptance Parameters		Value
Length of Bills/Vouchers Accepted		120 ÷ 166 mm
Width of Bills/Vouchers Accepted		62 ÷ 83 or 85 mm
Bill/Voucher Validation and Stacking Time		~ 3s
Cassette Capacity		Up to 500 bills/vouchers

CashCode MFL		
Electrical Parameters		Value
Power Supply Voltage		12V DC ± 10%
Current consumption	Standby	0.2 A
	Operating mode	max 2 A
Power consumption	Standby	2.4 W
	Operating mode	12 W
Communication Interface		RS232
Environment Parameters		Value
Operating Temperature		0°C ÷ +50°C
Storage Temperature		-30°C ÷ +60°C
Operating Relative Humidity		30% ÷ 90%
Acceptance Parameters		Value
Validation rate		≥96%
Length of Bills/Vouchers Accepted		124 ÷ 172 mm
Width of Bills/Vouchers Accepted		62 ÷ 82 mm
Bill/Voucher Validation and Stacking Time		max 4.5 s
Cassette Capacity		600 bills/vouchers

JCM UBA-10-SS / JCM iPro		
Electrical Parameters		Value
Power Supply Voltage		12V DC \pm 5%
Current consumption	Standby	0.3 A
	Operating mode	1.6 A
Communication Interface		RS232
Environment Parameters		Value
Operation Temperature		+5°C \div +50°C
Operating Relative Humidity		30% \div 85%
Storage Relative Humidity		30% \div 86%
Acceptance parameters		Value
Length of Bills/Vouchers Accepted		120 \div 165 mm
Width of Bills/Vouchers Accepted		62 \div 85 mm
Bill/Voucher Validation and Stacking Time		~ 5 s
Cassette Capacity		500 bills/vouchers

JCM iVizion		
Electrical Parameters		Value
Power Supply Voltage		12V DC - 5% to 24V DC +10%
Current consumption	Standby	24V DC - 0.2 A, 12V DC - 0.2 A
	Operating mode	24V DC - 1.3 A, 12V DC - 2.3 A
	Maximum	24V DC - 3.2 A, 12V DC - 3.0 A
Communication Interface		RS232
Environment Parameters		Value
Operation Temperature		+5°C \div +50°C
Operating Relative Humidity		15% \div 85%
Storage Temperature		15% \div 85%
Acceptance Parameters		Value
Length of Bills/Vouchers Accepted		110 \div 170 mm
Width of Bills/Vouchers Accepted		60 \div 85 mm
Bill/Voucher Validation and Stacking Time		~ 5s
Cassette Capacity		500 bills/vouchers

NV 200		
Electrical Parameters		Value
Power Supply Voltage		12V DC \pm 10%
Current consumption	Standby	0.4 A
	Operating mode	3A/ max 5 A
Communication Interface		RS232. USB 2.0
Environment Parameters		Value
Operation Temperature		0° C \div +50° C
Operating Relative Humidity		30% \div 90%
Storage Temperature		-30° C \div +60° C
Acceptance Parameters		Value
Validation Rate		\geq 96%
Length of Bills/Vouchers Accepted		115 \div 170 mm
Width of Bills/Vouchers Accepted		60 \div 85 mm
Bill/Voucher Validation and Stacking Time		max 4.5s
Cassette Capacity		Up to 500 bills/vouchers

NV 200 Spectral		
Electrical Parameters		Value
Power Supply Voltage		12V DC \pm 10%
Current consumption	Standby	0.35 A
	Operating mode	1.5A/ max 3.5 A
Communication Interface		RS232, USB 2.0
Environment Parameters		Value
Operation Temperature		0° C \div +50° C
Operating Relative Humidity		30% \div 90%
Storage Temperature		-30° C \div +60° C
Acceptance Parameters		Value
Validation Rate		\geq 96%
Length of Bills/Vouchers Accepted		115 \div 170 mm
Width of Bills/Vouchers Accepted		60 \div 85 mm
Bill/Voucher Validation and Stacking Time		max 4.5s
Cassette Capacity		Up to 500 bills/vouchers

iCT NBA		
Electrical Parameters		
Value		
Power Supply Voltage		12V DC \pm 10% to 24 V DC \pm 10%
Current consumption	Standby	0.35 A
	Operating mode	1.25A
	Maximum	3.5 A
Communication Interface		RS232, USB 2.0
Environment Parameters		Value
Operation Temperature		0° C \div +50° C
Operating Relative Humidity		30% \div 95%
Storage Temperature		-30° C \div +70° C
Acceptance Parameters		Value
Validation Rate		\geq 96%
Length of Bills/Vouchers Accepted		115 \div 170 mm
Width of Bills/Vouchers Accepted		62 \div 83 mm
Bill/Voucher Validation and Stacking Time		max 5s
Cassette Capacity		Up to 500 bills/vouchers

JCM UBA PRO 500SS		
Electrical Parameters		
Value		
Power Supply Voltage		12V DC - 5% to 24 V DC + 5%
Current consumption	Standby	0.4 A
	Operating mode	3.6A
	Maximum	4.0 A
Communication Interface		RS232, USB 2.0
Environment Parameters		Value
Operation Temperature		5° C \div +50° C
Operating Relative Humidity		15% \div 85%
Storage Temperature		-20° C \div +60° C
Acceptance Parameters		Value
Validation Rate		\geq 98%
Length of Bills/Vouchers Accepted		120 \div 165 mm
Width of Bills/Vouchers Accepted		62 \div 85 mm
Bill/Voucher Validation and Stacking Time		2.2 s
Cassette Capacity		Up to 500 or 900 bills/vouchers

Components

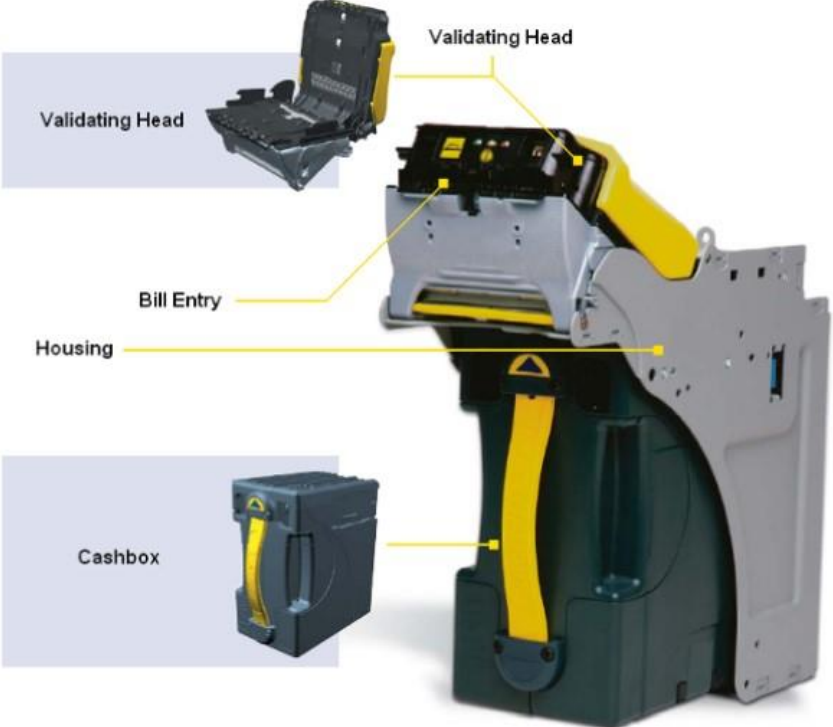
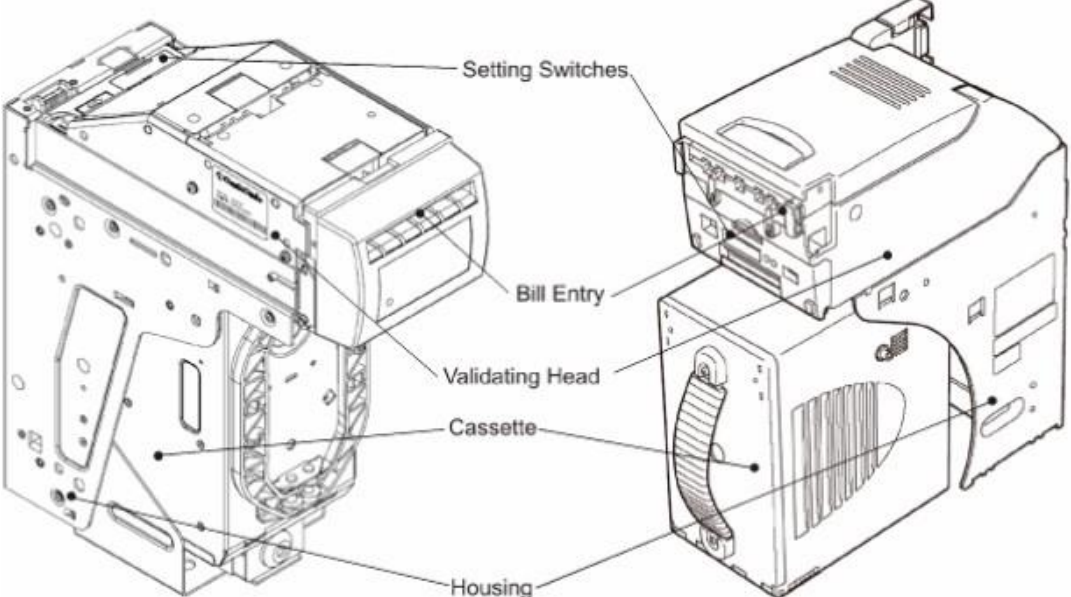
Bill Validator Model	Components
<p><i>MEI SCN8347(E)</i></p>	 <p>A photograph of the MEI SCN8347(E) bill validator. The device is primarily grey and black with a prominent yellow handle. Callout lines point to the following components: 'Validating Head' (top), 'Bill Entry' (middle), 'Housing' (main body), and 'Cashbox' (bottom). Two inset images show the 'Validating Head' and 'Cashbox' separately.</p>
<p><i>Cashcode MFL and JCM UBA-10-SS</i></p>	 <p>An exploded view diagram of the Cashcode MFL and JCM UBA-10-SS bill validator. The diagram shows the internal and external components of the device. Callout lines point to the following components: 'Setting Switches' (top), 'Bill Entry' (middle), 'Validating Head' (lower middle), 'Cassette' (bottom), and 'Housing' (base).</p>

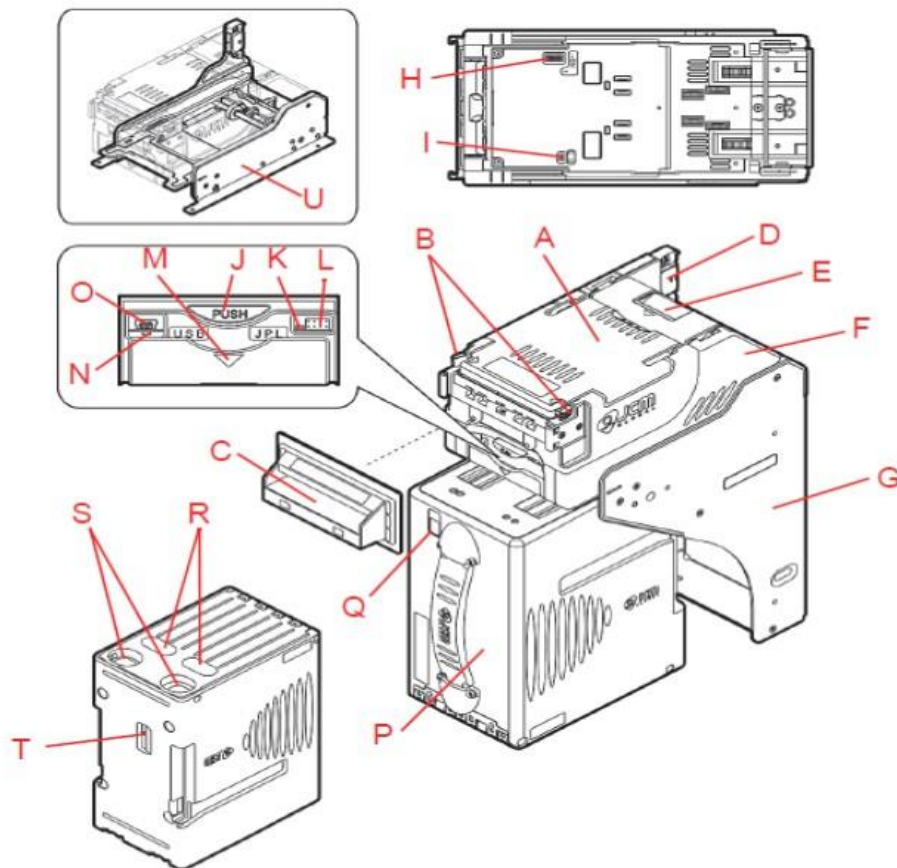

JCM iPro
JCM iVision

A	Acceptor Unit	L	Front Panel Bezel JPL Connector
B	Front Upper Guide Access Lever (Acceptor Unit)	M	Transport Unit Release Lever
C	Bezel (Option) - use from JCM iPro model!	N	Power ON LED (Green)
D	Interface Connector	O	USB (mini-B) Software Download/Calibration & Maintenance Connector
E	Rear Upper Guide Access Lever (Transport Unit)	P	Cash Box
F	Transport Unit	Q	Stack Volume Indicator Window
G	Frame Housing (SS Specification)	R	Cash Box Window – confirms the last stacked Banknote Denomination Value
H	DIP Switch Block (Denomination INHIBIT)	S	Lock Installation Hole (user-provided)
I	DIP Switch Block (JCM Custom Private Line)	T	Pusher Lever – manually moves the Pusher Plate down (Activate the lever to confirm the denomination value through Cash Box Windows “R”).
J	Acceptor Unit Release Pushbutton	U	Frame Housing (LD Version).
K	Status LED (Four (4) colors: Red/Yellow/Green & Blue)		

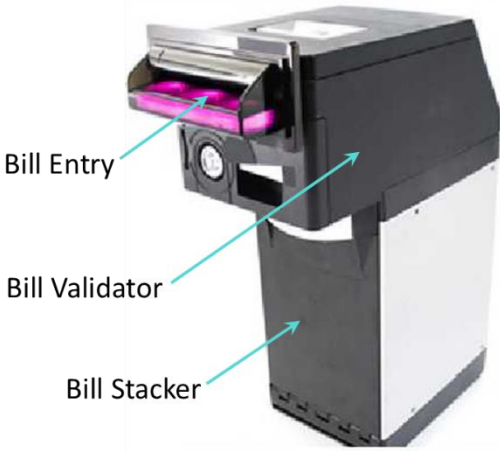
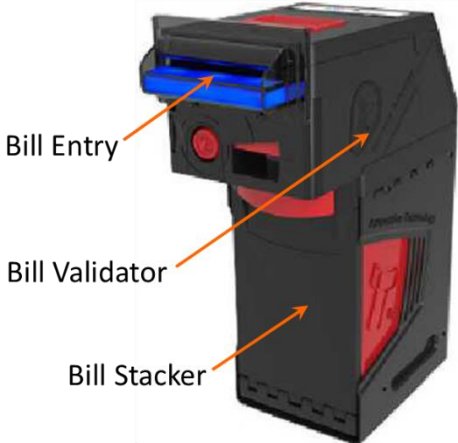
Bill Validator Model	Components
<p>NV 200</p>	 <p>Bill Entry</p> <p>Bill Validator</p> <p>Bill Stacker</p>
<p>NV 200 Spectral</p>	 <p>Bill Entry</p> <p>Bill Validator</p> <p>Bill Stacker</p>

Collecting Bills

Collecting bills from CashCode MFL

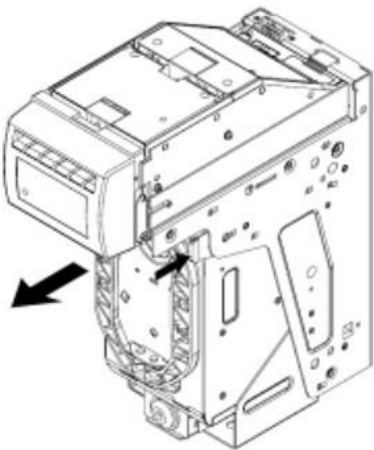

- 1 -

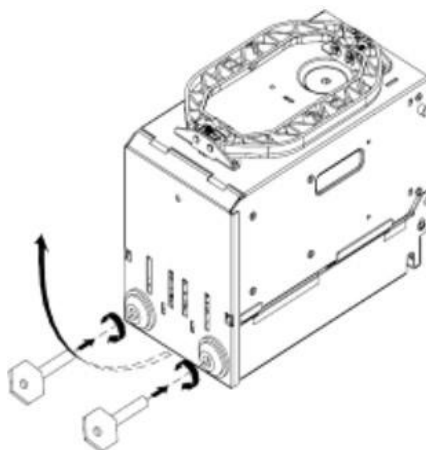

- 2 -

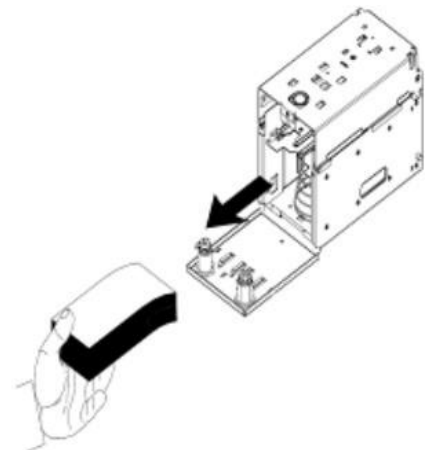

- 3 -

1. Open the bill validator door.
2. Push the lever, pointed by the small arrow in picture 1 above, and pull the cassette out.
3. Unlock the cassette cover by inserting appropriate keys in the locks and turning clockwise, as shown in picture 2 above. Open the cover.

4. Take the bills, as shown in picture 3 above.
5. Lock the cassette and put it back into the housing.

Collecting bills from JCM UBA-10-SS

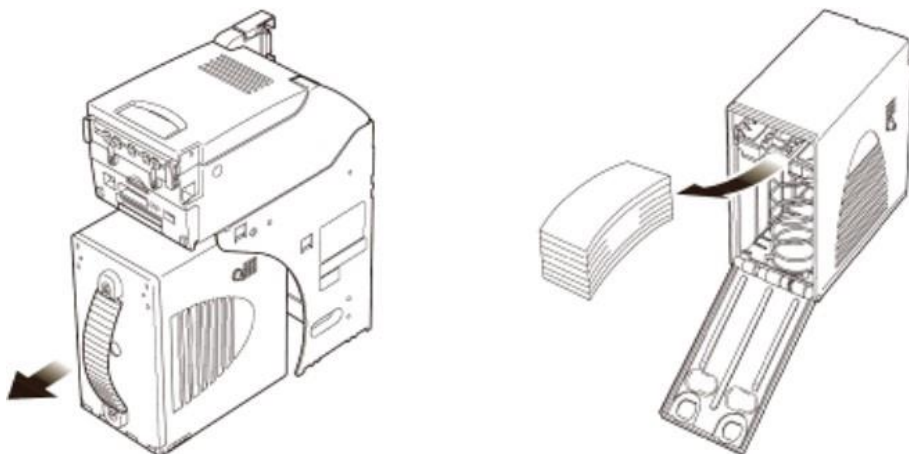

-1-

-2-

1. Open the bill validator door.
2. Hold the cassette handle and pull it in the direction, pointed by the arrow in picture 1 above.
3. Open the cover and take the bills, pointed by the arrow in picture 2 above.
4. Put back the cassette into the housing.

Removing Jammed Bills

Removing Jammed Bills from CashCode MFL

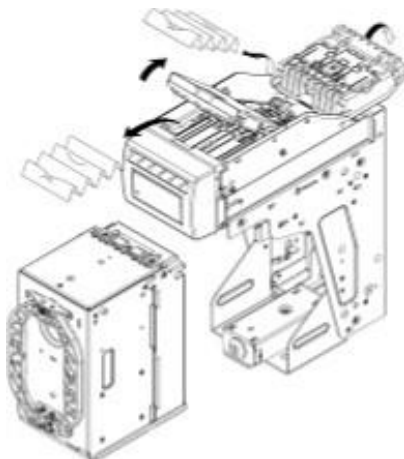

Depending on the situation encountered jammed bills must be removed as shown in the picture above.

Removing bills from JCM UBA-10-SS

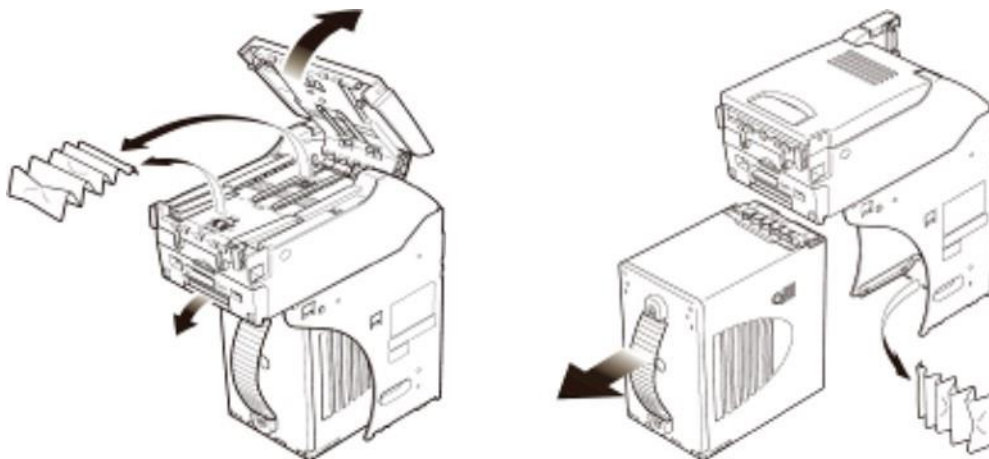

Depending on the situation encountered jammed bills must be removed as shown in the picture above.

Configuring the Bill Validator

Configuring CashCode MFL

CashCode MFL configuration is done by setting switches, located at the rear end of the validating head, under a transparent plastic cover.

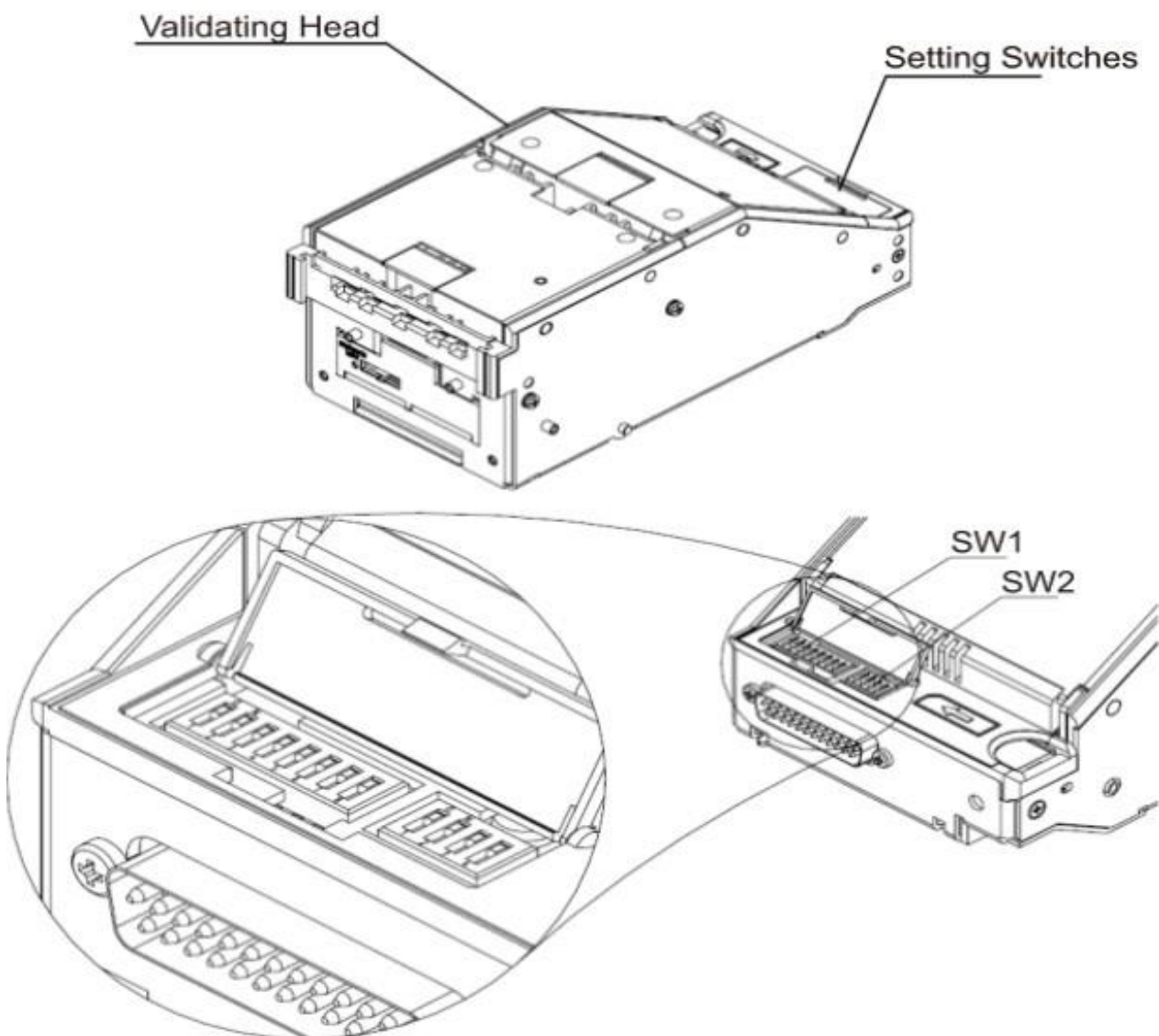

CashCode MFL operates in two basic modes: validation and service.

Defining settings, operating mode, and enabled denominations are performed by two groups of switches - **SW1** and **SW2**.

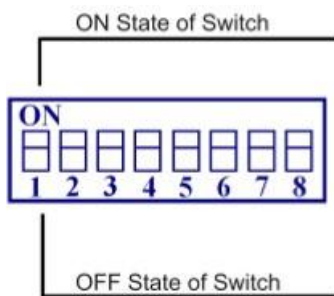

The function of the group of **SW1 DIP** switches is the following:

Switch	ON	OFF
SW 1.1	Denomination 1 enabled	Denomination 1 disabled
SW 1.2	Denomination 2 enabled	Denomination 2 disabled
SW 1.3	Denomination 3 enabled	Denomination 3 disabled
SW 1.4	Denomination 4 enabled	Denomination 4 disabled
SW 1.5	Denomination 5 enabled	Denomination 5 disabled
SW 1.6	Denomination 6 enabled	Denomination 6 disabled
SW 1.7	Denomination 7 enabled	Denomination 7 disabled
SW 1.8	Denomination 8 enabled	Denomination 8 disabled

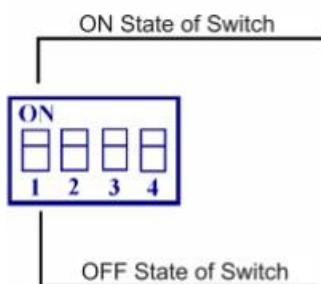

CashCode MFL SW2 Setting switches condition

Parameters	Switch	On	Off
Orientation of the bill	SW 2.1	Four-way	One-way
	SW 2.2	Not used	Not used
Interface communication speed	SW 2.3	9600 bps	19,200 bps
Operating Mode	SW 2.4	Service Mode	Validation Mode

For additional information on switch features and explanations, please see CashCode MFL User Manual.

Configuring JCM UBA-10-SS

JCM UBA-10-SS operates in two modes: test and normal.

Defining settings, operating mode, and enabled denominations are performed by setting switches.

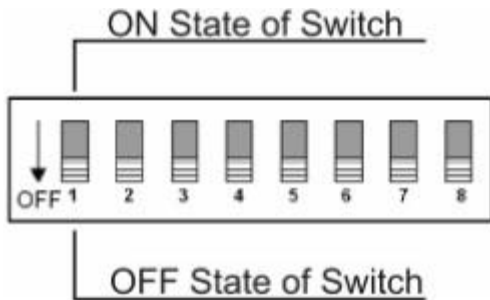

Switch	ON	OFF
1	Accept of barcode vouchers disabled	Accept of barcode vouchers enabled
2	Denomination 1 disabled	Denomination 1 enabled
3	Denomination 2 disabled	Denomination 2 enabled
4	Denomination 3 disabled	Denomination 3 enabled
5	Denomination 4 disabled	Denomination 4 enabled
6	Denomination 5 disabled	Denomination 5 enabled
7	Denomination 6 disabled	Denomination 6 enabled
8	Test Mode	Normal Mode

* By default, all switches are in the OFF position

For additional information on switch features and explanations, please see JCM UBA-10-SS User Manual.

Configuring JCM iVizion 100 ss

JCM iVizion 100 ss Denomination DIP switch settings (SW1 DIP switch)

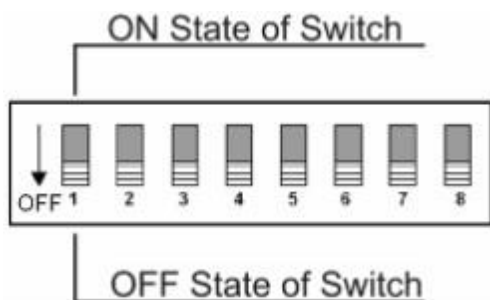

Set all SW1 switches in the OFF position as shown in the picture above.

JCM iVizion-SS Serial Communication DIP switches settings:



Set the two switches in the shown position in the picture above (opposite the Mark) to use the RS232 communication interface.

Ticket Printers Models and Technical Parameters

Type

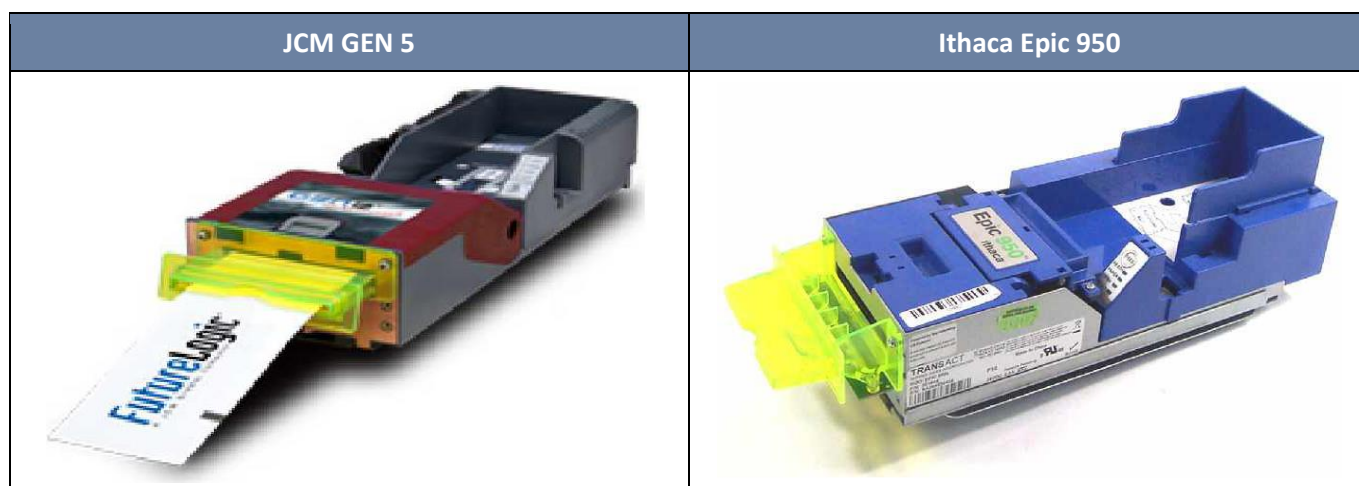

Technical parameters

JCM GEN 5		
Electrical Parameters		Value
Power Supply Voltage:		24 V DC \pm 5%
Current consumption	At 24 V and 25% black	max 2.7 A
Communication Interface		RS 232
Environment Parameters		Value
Operation Temperature		+5°C \div +50°C
Storage Temperature		-20°C \div 75°C
Operating Relative Humidity		5% \div 85%
Print Parameters		Value
Print Method		Direct Thermal, Top Coated, Fanfolded, and Perforated
Print Speed (monochrome, in text mode)		90 mm/sec
Resolution		203 dpi x 203 dpi
Print Width		62 mm
Tickets capacity		300 vouchers
Ticket Parameters		Value
Ticket Width		66 mm
Ticket Length (between perforations)		156 \pm 1 mm
Ticket Thickness		4,5 mil, 1 color / 2 colors

Ithaca Epic 950		
Electrical Parameters		Value
Power Supply Voltage:		24 V DC \pm 10%
Current consumption	At 24 V and 25% black	max 2.2 A
Communication Interface		RS 232
Environment Parameters		Value
Operation Temperature		+5°C \div +45°C
Storage Temperature		-10°C \div 50°C
Operating Relative Humidity		10% \div 90%
Print Parameters		Value
Print Method		Thermal
Print Speed (monochrome, in text mode)		125 mm/sec
Resolution		203 dpi x 203 dpi
Print Width		62 mm
Tickets capacity		400 vouchers
Ticket Parameters		Value
Ticket Width		65 \pm 1 mm
Ticket Length (between perforations)		156 \pm 1 mm
Ticket Thickness		0.114 \div 0.127 mm

Loading Tickets

Loading tickets in JCM GEN 5 ticket printer

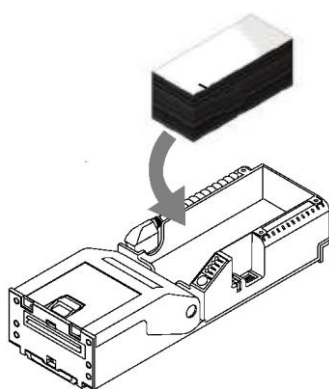

-1-

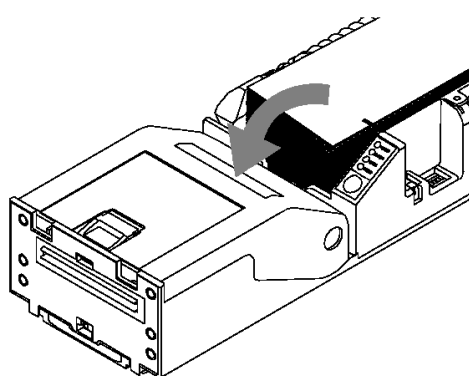

-2-

1. Load tickets into the ticket supply tray, so that it lays flat as shown in picture 1 above.
2. Insert the leading ticket into the ticket in the slot as shown in picture 2 above.

Loading tickets in **Ithaca Epic 950** ticket printer

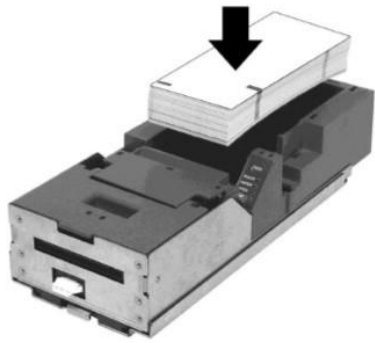

-1-

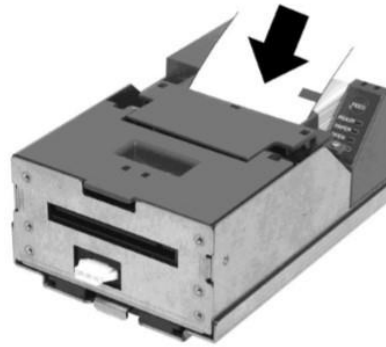

-2-

1. Load tickets into the ticket supply tray, making sure that the black dot is positioned as shown in picture 1 above.
2. Insert the leading ticket into the printer mechanism's insertion guide area – picture 2 above. The ticket should be fed about a ½" into the mechanism; at this time, the machine automatically completes the feeding process.

Modular Diagrams of Components

Power

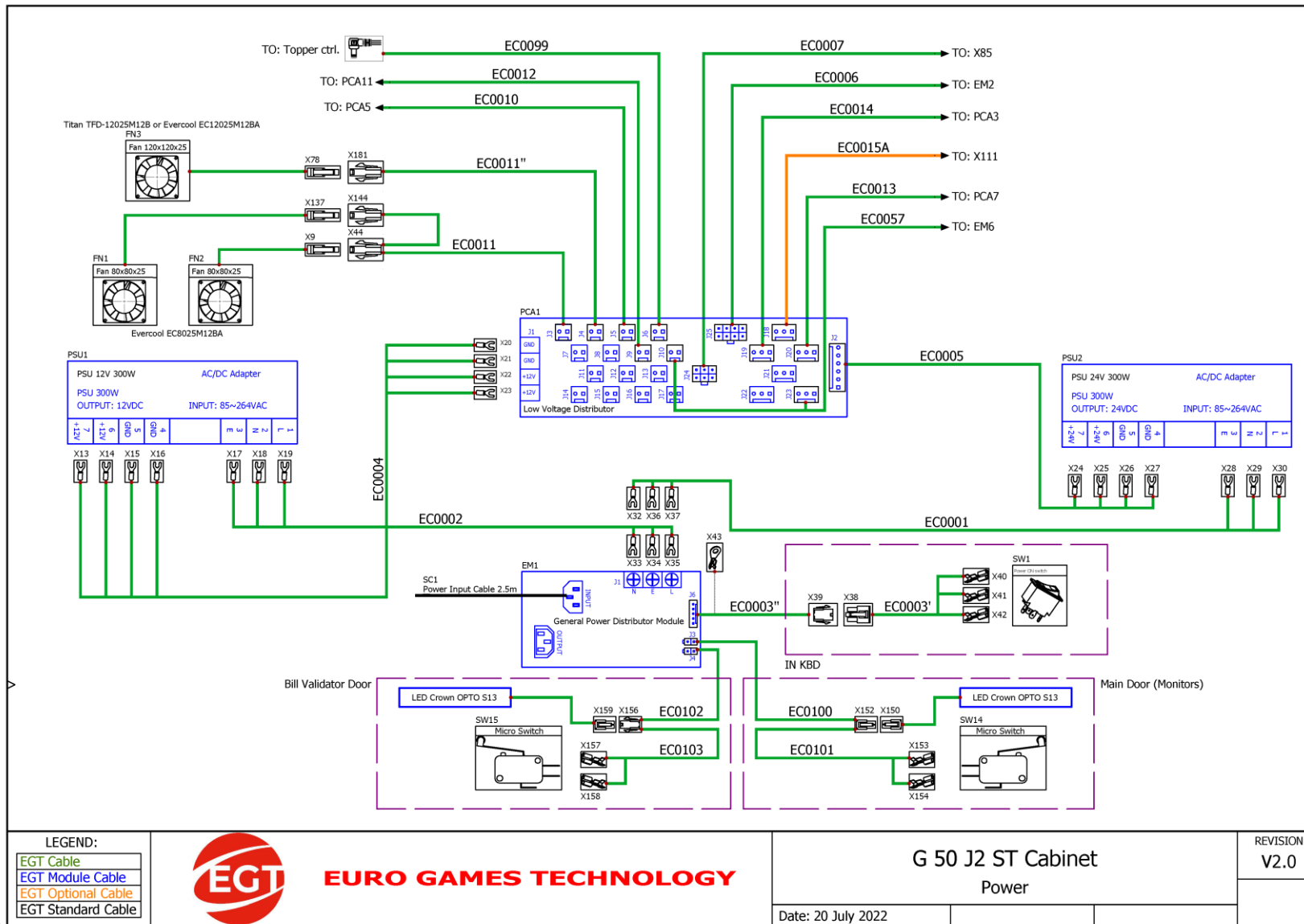

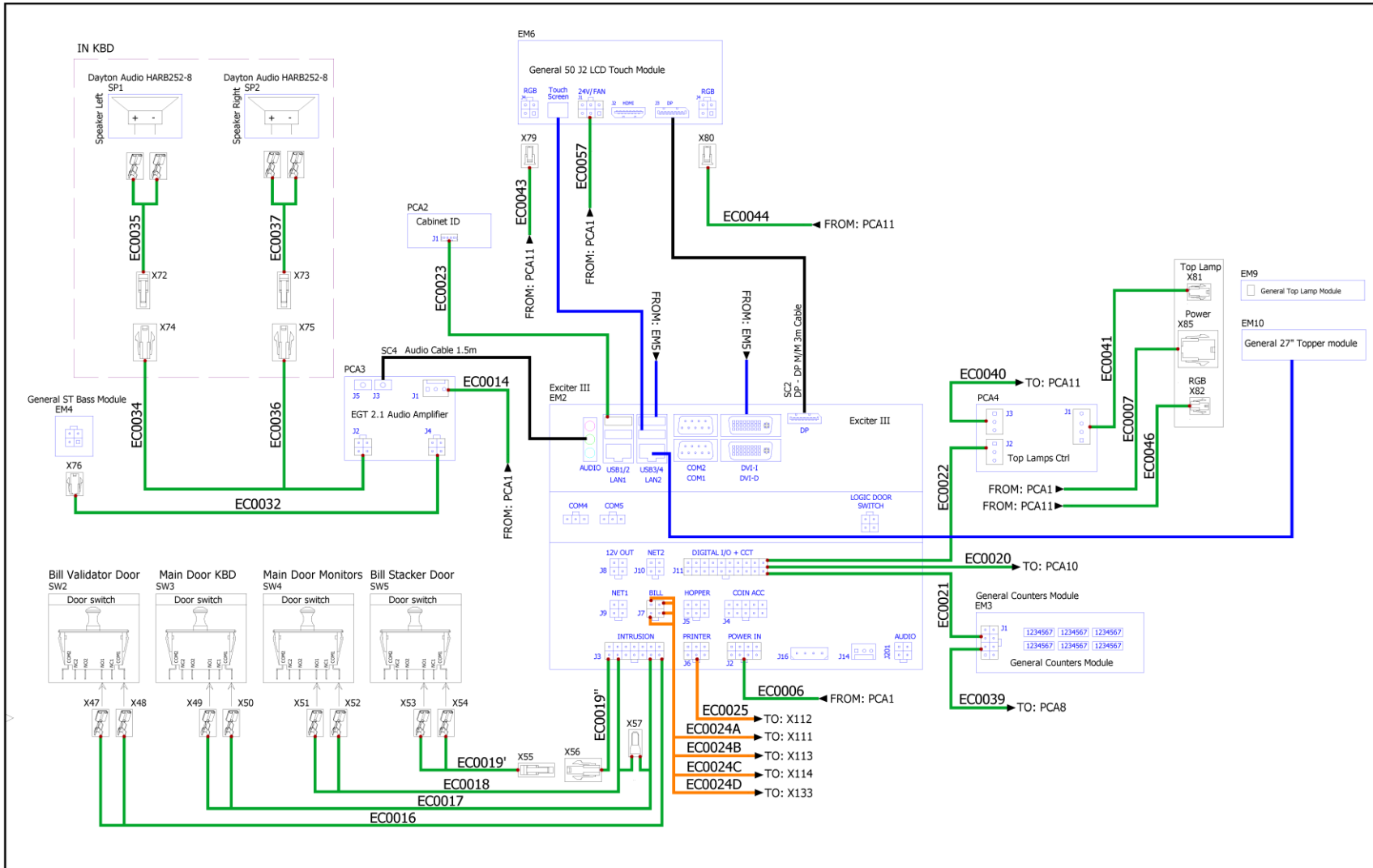

LEGEND:

EGT Cable
EGT Module Cable
EGT Optional Cable
EGT Standard Cable



G 50 J2 ST Cabinet
Exciter III

REVISION
V1.2

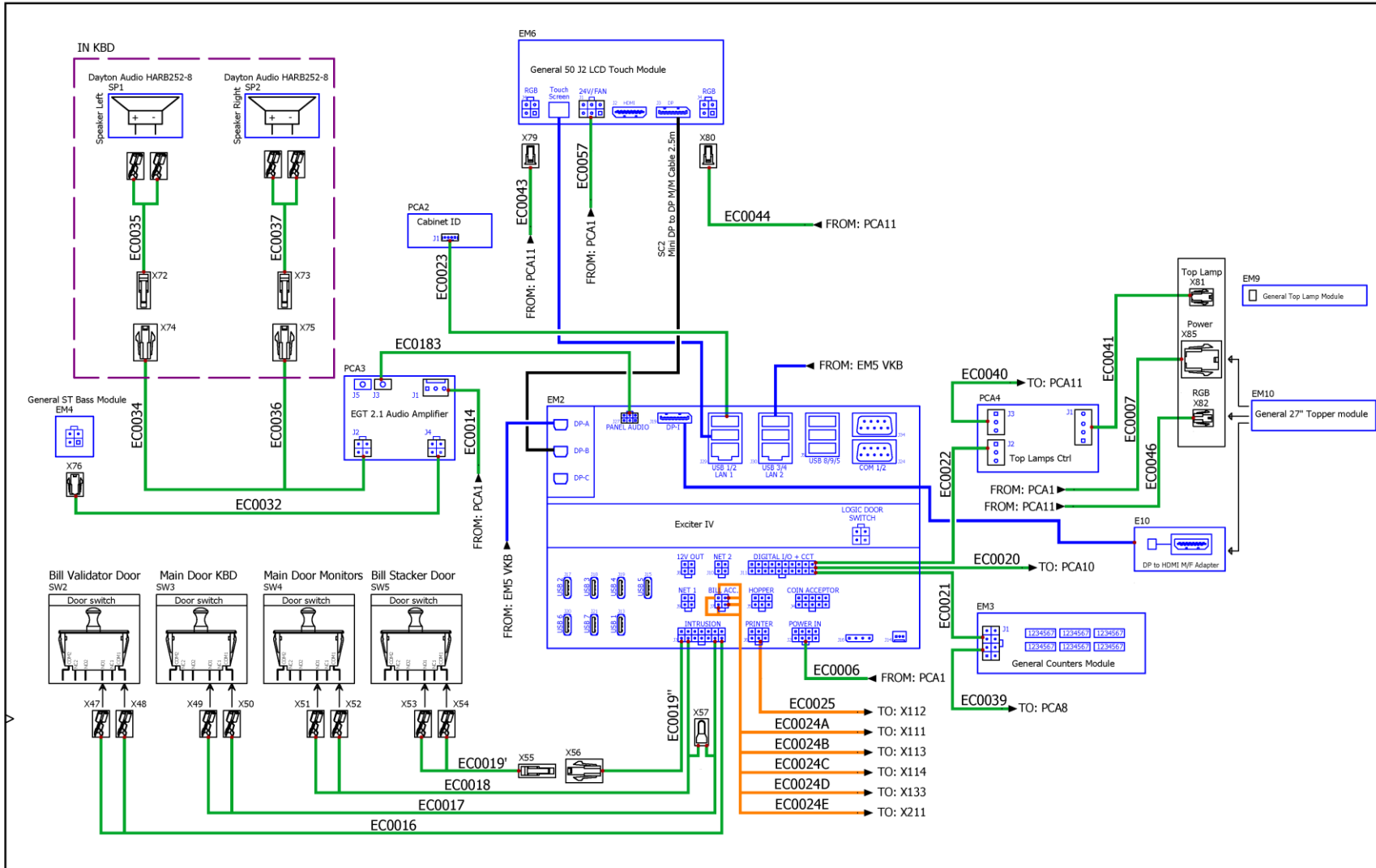

LEGEND:

EGT Cable
EGT Module Cable
EGT Optional Cable
EGT Standard Cable



EURO GAMES TECHNOLOGY

G 50 J2 ST Cabinet
Exciter IV

REVISION
V2.0

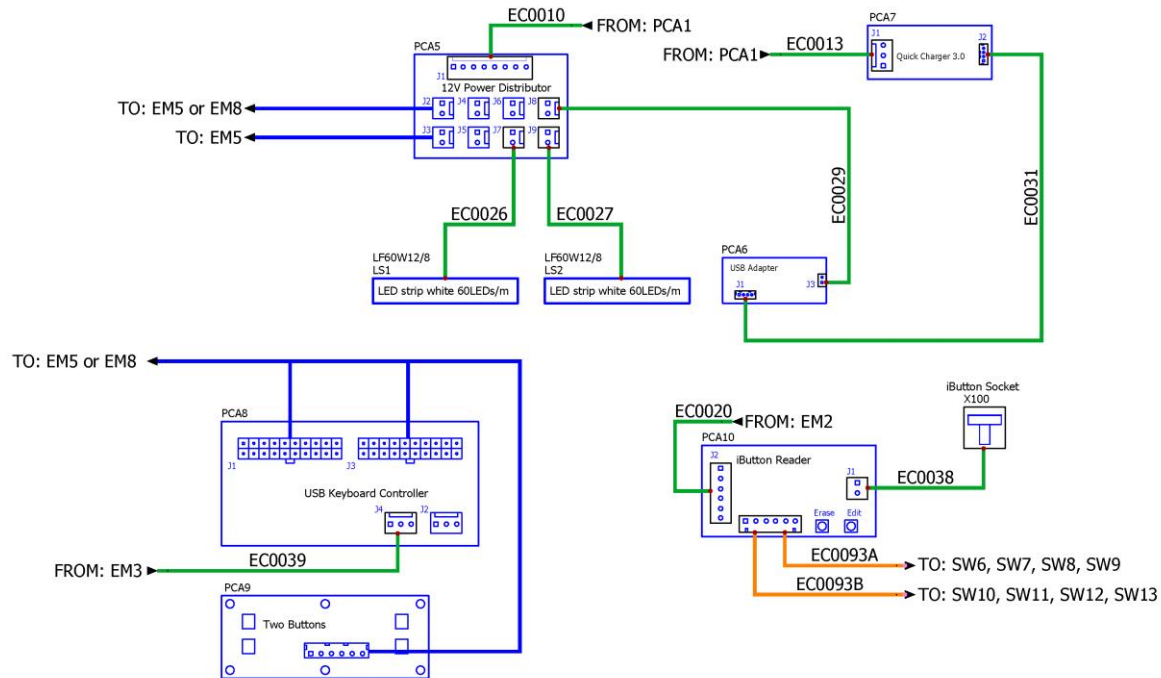

LEGEND:	
—	EGT Cable
—	EGT Module Cable
—	EGT Optional Cable
—	EGT Standard Cable



EURO GAMES TECHNOLOGY

G 50 J2 ST Cabinet
KBD

REVISION
V2.0

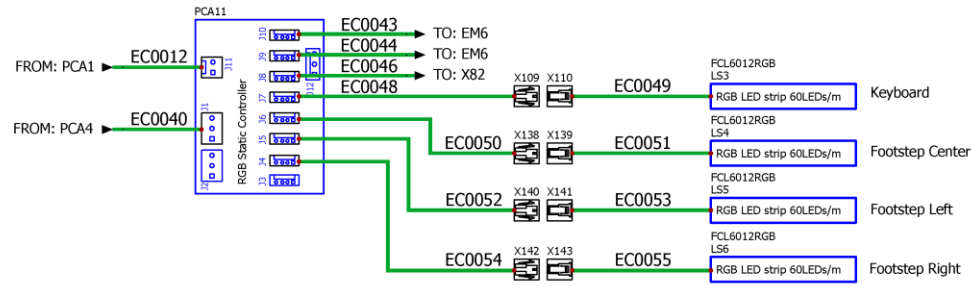

LEGEND:

EGT Cable
EGT Module Cable
EGT Optional Cable
EGT Standard Cable



EURO GAMES TECHNOLOGY

G 50 J2 ST Cabinet
RGB Lights

REVISION
V2.0

Optional Peripherals



Note:

The bill validators **NV200** and **NV200 Spectral** are used only in gaming machine with **Exciter IV** platform.

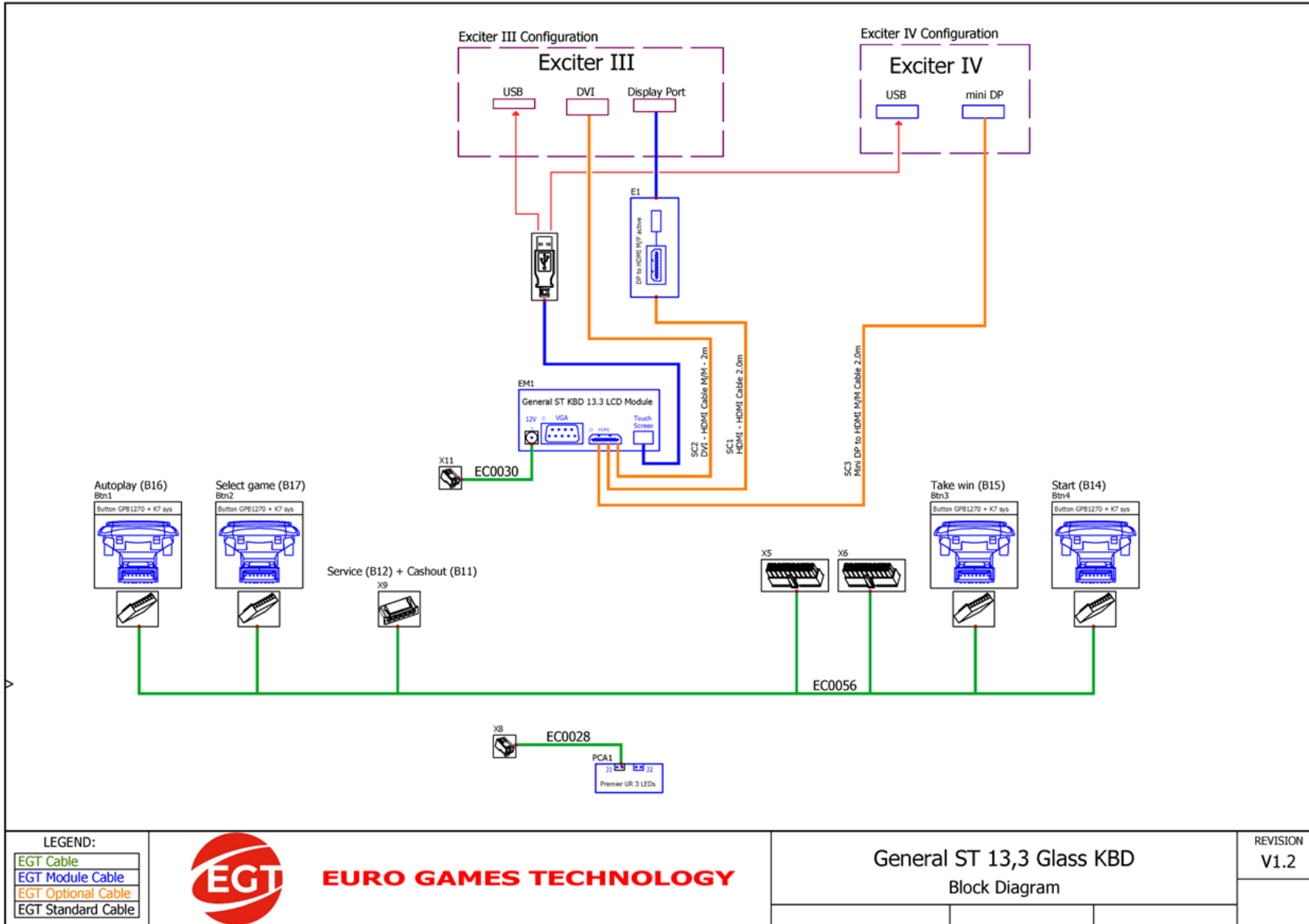

Monitor and Touchscreen of the Dynamic Touch Keyboard

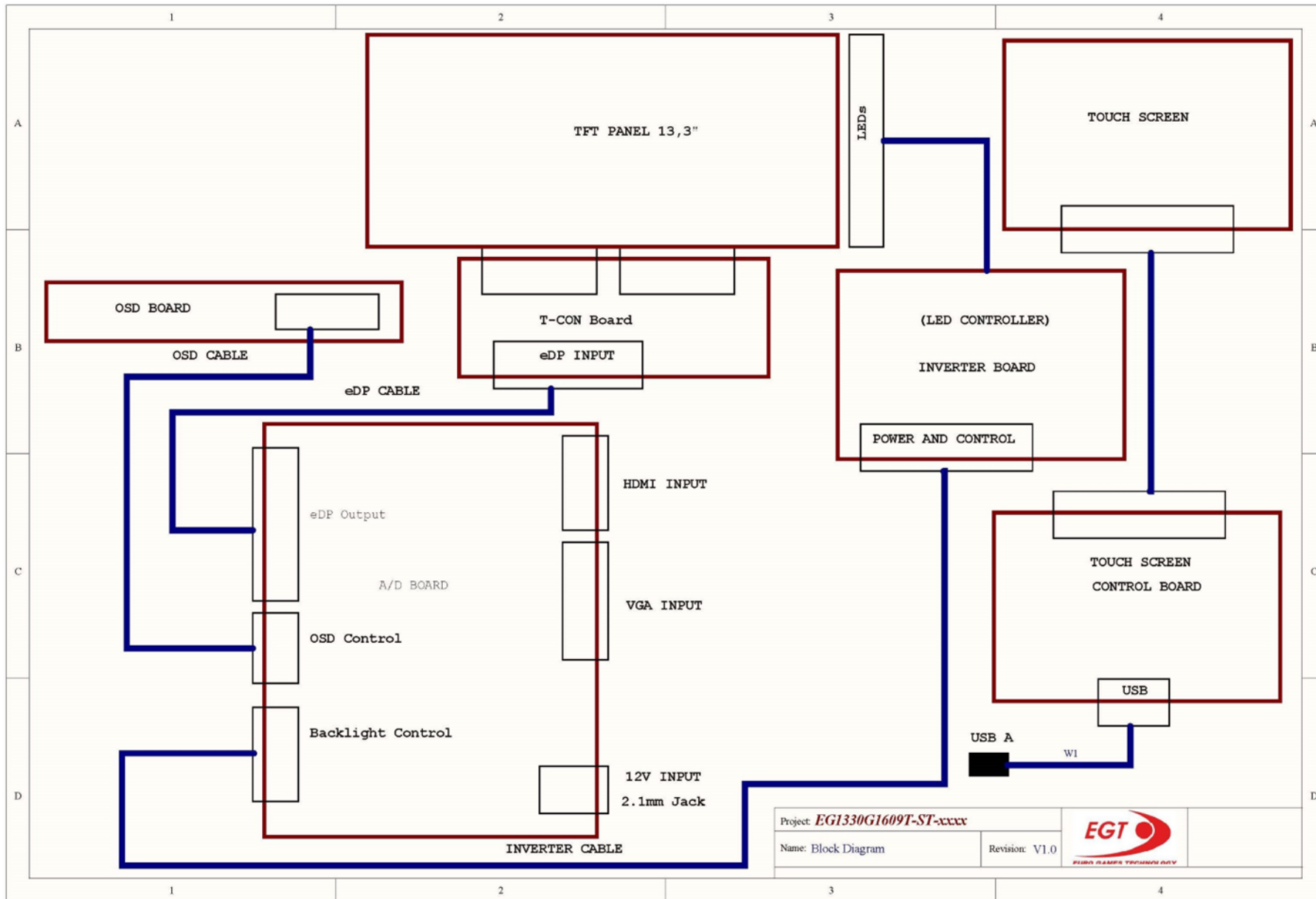

50" EGT Monitor with Touchscreen

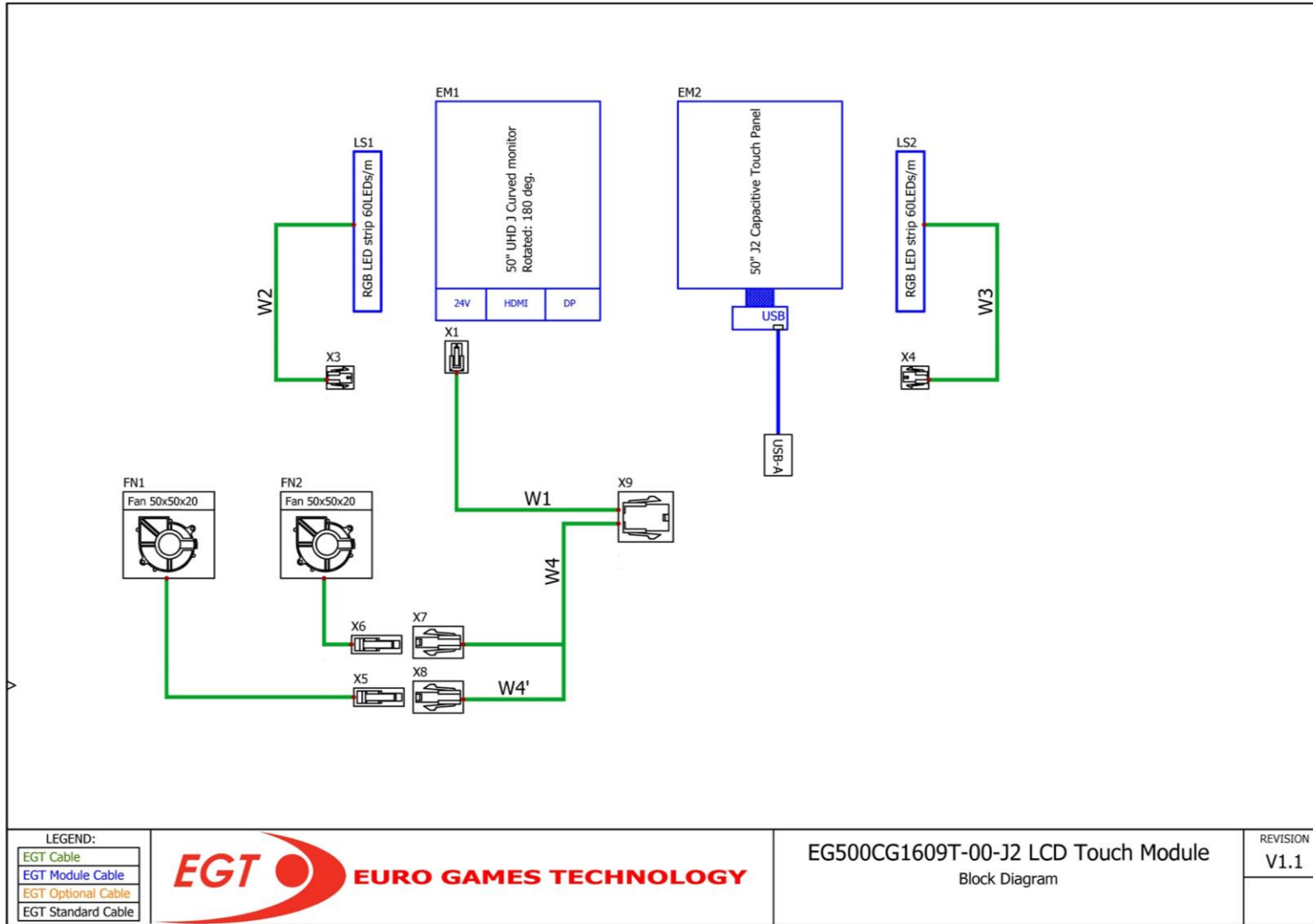

Connectors of Backplane Board

P1		BH40S 2x20 pin male	
PIN No	Signal Name	PIN No	Signal Name
1	T_RXD4	2	T_TXD4
3	T_RXD7	4	T_TXD7
5	T_RXD5	6	T_TXD5
7	T_RXD6	8	T_TXD6
9	T_RXD2	10	T_TXD2
11	T_RXD3	12	T_TXD3
13	GND	14	DIN0
15	DIN1	16	DIN2
17	DIN3	18	DIN4
19	DIN5	20	DIN6
21	DIN7	22	DIN8
23	DIN9	24	DIN10
25	DIN11	26	DOUT0
27	DOUT1	28	DOUT2
29	DOUT3	30	DOUT4
31	DOUT5	32	DOUT6
33	DOUT7	34	INTRUSION0
35	INTRUSION1	36	INTRUSION2
37	INTRUSION3	38	INTRUSION4
39	INTRUSION5	40	INTRUSION6

J2		POWER INPUT	
MOLEX 4x2pin mini-fit Straight			
PIN No	Signal Name	PIN No	Signal Name
1	+12V	5	+12V
2	+12V	6	GND
3	GND	7	GND
4	GND	8	+24V

J3 INTRUSION SWITCHES			
MOLEX 7x2pin Mini-fit Straight			
PIN No	Signal Name	PIN No	Signal Name
1	INTRUSION0	8	GND
2	INTRUSION1	9	GND
3	INTRUSION2	10	GND
4	INTRUSION3	11	GND
5	INTRUSION4	12	GND
6	INTRUSION5	13	GND
7	INTRUSION6	14	GND

J6 Serial Ticket Printer			
MOLEX 3x2pin Mini-fit Straight			
PIN No	Signal Name	PIN No	Signal Name
1	R_RXD7	4	+24V / 3A
2	R_TXD7	5	EXT_DIN11
3	GND	6	GND

J7 Serial Bill Acceptor			
MOLEX 2x2pin Mini-fit Straight			
PIN No	Signal Name	PIN No	Signal Name
1	R_RXD4	3	GND
2	R_TXD4	4	+12V / 3A

J8 12V OUT			
MOLEX 2x2pin Mini-fit Straight			
PIN No	Signal Name/Current	PIN No	Signal Name/Current
1	N.C.	3	GND
2	N.C.	4	+12V / 1.5A

J9 Casino Net 1			
MOLEX 2x2pin Mini-fit Straight			
PIN No	Signal Name/Current	PIN No	Signal Name/Current
1	R_RXD2	3	GND
2	R_TXD2	4	+12V / 1.5A

J10 Casino Net 2			
MOLEX 2x2pin Mini-fit Straight			
PIN No	Signal Name/Current	PIN No	Signal Name/Current
1	R_RXD3	3	GND
2	R_TXD3	4	+12V / 1.5A

J11 ccTalk and DIGITAL I/O			
MOLEX 10x2pin Mini-fit Straight			
PIN No	Signal Name	PIN No	Signal Name
1	GND	11	GND
2	CCT-DAT	12	CCT-DAT (COM7)
3	+12V / 3A	13	+12V / 3A
4	+12V / 3A	14	+12V / 3A
5	OC0	15	OC1
6	OC2	16	OC3
7	GND	17	GND
8	GND	18	GND
9	EXT_DIN0	19	EXT_DIN1
10	EXT_DIN2	20	EXT_DIN3

J14 Cabinet FANS	
CviLux CI3103P1V00	
PIN No	Signal Name
1	GND
2	+12V / 1.5A
3	N.C.

J16	HDD POWER OUTPUT		
	AMP 350211		
PIN No	Signal Name/Current	PIN No	Signal Name/Current
1	+12V / 1.5A	3	GND
2	GND	4	+5V

J1	UPS POWER V1.6		
	MOLEX 2x2pin Mini-fit Straight		
PIN No	Signal Name/Current	PIN No	Signal Name/Current
1	GND	3	BU+12V
2	GND	4	BU+12V

J1	UPS POWER V2.2		
	MOLEX 3x2pin Mini-fit Straight		
PIN No	Signal Name/Current	PIN No	Signal Name/Current
1	GND	4	BU+12V
2	GND	5	BU+12V
3	GND	6	BU+12V

Contacts

Euro Games Technology Ltd.

BULGARIA

Head Office

Address

6 Panorama Sofia Str., Sofia Park
RichHill Business Center, Block A
1756 Sofia, BULGARIA

EGT Technical Support - Head Office

Phone: +359 2 890 24 68

Fax: +359 2 890 24 88

Mobile: +359 896 71 02 72

e-mail: service@egt-bg.com; parts@egt-bg.com

EGT Sales - Head Office

Phone: +359 2 890 24 00

Fax: +359 2 890 24 88

e-mail: sales@egt-bg.com